

Under this heading will appear the text of proposed rules and changes. The notice of proposed rulemaking is required to contain an explanation of any new rule or any change in an existing rule and the reasons therefor. This is set out in the Purpose section with each rule. Also required is a citation to the legal authority to make rules. This appears following the text of the rule, after the word "Authority."

Entirely new rules are printed without any special symbolology under the heading of the proposed rule. If an existing rule is to be amended or rescinded, it will have a heading of proposed amendment or proposed rescission. Rules which are proposed to be amended will have new matter printed in boldface type and matter to be deleted placed in brackets.

An important function of the *Missouri Register* is to solicit and encourage public participation in the rulemaking process. The law provides that for every proposed rule, amendment or rescission there must be a notice that anyone may comment on the proposed action. This comment may take different forms.

If an agency is required by statute to hold a public hearing before making any new rules, then a Notice of Public Hearing will appear following the text of the rule. Hearing dates must be at least thirty (30) days after publication of the notice in the *Missouri Register*. If no hearing is planned or required, the agency must give a Notice to Submit Comments. This allows anyone to file statements in support of or in opposition to the proposed action with the agency within a specified time, no less than thirty (30) days after publication of the notice in the *Missouri Register*.

An agency may hold a public hearing on a rule even though not required by law to hold one. If an agency allows comments to be received following the hearing date, the close of comments date will be used as the beginning day in the ninety (90)-day-count necessary for the filing of the order of rulemaking.

If an agency decides to hold a public hearing after planning not to, it must withdraw the earlier notice and file a new notice of proposed rulemaking and schedule a hearing for a date not less than thirty (30) days from the date of publication of the new notice.

Proposed Amendment Text Reminder:

Boldface text indicates new matter.

[Bracketed text indicates matter being deleted.]

**Title 2—DEPARTMENT OF AGRICULTURE
Division 30—Animal Health
Chapter 2—Health Requirements for
Movement of Livestock, Poultry and Exotic Animals**

PROPOSED AMENDMENT

2 CSR 30-2.010 Health Requirements Governing the Admission of Livestock, Poultry and Exotic Animals Entering Missouri.
The division is amending subsection (13)(D).

PURPOSE: This proposed amendment addresses the financial crisis affecting Missouri white-tail deer farmers due to the importation restriction implemented during the first years of chronic wasting disease (CWD) control and eradication efforts throughout the nation by reducing the required level of surveillance for CWD in order for white-tail deer to enter Missouri.

(13) Miscellaneous and Exotic Animals. All exotic animals must be accompanied by an official Certificate of Veterinary Inspection showing an individual listing of the common and scientific name(s) of the animal(s) and appropriate descriptions of animal(s) such as sex, age, weight, coloration and the permanent tag number, brand or tattoo identification.

(D) Captive cervids, prior to entering Missouri, must have an entry permit issued by the state veterinarian's office and a Certificate of Veterinary Inspection. Captive cervids that enter Missouri must be in compliance with the guidelines as incorporated by reference to the *Bovine Tuberculosis Eradication Uniform Methods and Rules, Effective January 22, 1999* and *Brucellosis in Cervidae: Uniform Methods and Rules, Effective September 30, 1998*.

1. All sexually intact animals six (6) months of age or older, not under quarantine and not affected with brucellosis, must test negative for brucellosis within thirty (30) days prior to movement, except:

A. Brucellosis-free herd—captive cervids originating from certified brucellosis-free herds may enter on herd status without additional testing provided the certified herd number and current test date is shown on the Certificate of Veterinary Inspection;

B. Brucellosis-monitored herd—all sexually intact animals six (6) months of age or older must test negative for brucellosis within ninety (90) days prior to interstate movement.

2. Captive cervids not known to be affected with or exposed to tuberculosis and not in a status herd, as defined in the *Bovine Tuberculosis Eradication Uniform Methods and Rules, Effective January 22, 1999*, must have two (2) negative tuberculosis tests, not less than ninety (90) days apart, using the single cervical method. The second test must be within ninety (90) days prior to movement. Both negative test dates must be listed on the Certificate of Veterinary Inspection. Animals must have been isolated from other captive cervids during the testing period.

3. Movement from status herds.

A. Accredited herd—captive cervids originating from accredited tuberculosis-free cervid herd as defined by the *Bovine Tuberculosis Eradication Uniform Methods and Rules, Effective January 22, 1999*, may enter on herd status without additional testing provided the accredited herd number and current test date is shown on the Certificate of Veterinary Inspection.

B. Qualified herd—captive cervids originating from a qualified herd as defined by the *Bovine Tuberculosis Eradication Uniform Methods and Rules, Effective January 22, 1999*, must have one (1) negative tuberculosis test, using the single cervical method, within ninety (90) days prior to the date of movement.

C. Monitored herd—captive cervids originating from a monitored herd as defined by the *Bovine Tuberculosis Eradication Uniform Methods and Rules, Effective January 22, 1999*, must have one (1) negative tuberculosis test, using the single cervical method, within ninety (90) days prior to date of movement.

D. Captive cervids less than twelve (12) months of age that originate from and were born in qualified or monitored herds may be moved without further tuberculosis testing, provided that they are accompanied by a certificate stating that such captive cervids originated from such herds and have not been exposed to captive cervids from a lower status herd.

4. Captive cervids from an area that has been reported as a chronic wasting disease (CWD) endemic area or any cervid that has been in an endemic area in the last five (5) years will not be allowed to enter Missouri.

5. Elk, elk-hybrids, *[white-tailed deer]* and mule deer from all states must have participated in a surveillance program for at least three (3) years prior to entering Missouri. Other captive cervids **other than white-tailed deer** must have participated in a surveillance program recognized by the state of origin prior to entering Missouri.

6. White-tailed deer from all states must have participated in a surveillance program for at least two (2) years prior to entering Missouri. Other captive cervids must have participated in a surveillance program recognized by the state of origin prior to entering Missouri.

7. All captive white-tailed deer that enter Missouri with a two (2)-year status in a CWD surveillance program and remain in Missouri at the time of death must be tested for CWD.

AUTHORITY: section 267.645, RSMo 2000. This version of rule filed Jan. 24, 1975, effective Feb. 3, 1975. For intervening history, please consult the Code of State Regulations. Emergency amendment filed Aug. 23, 2004, effective Sept. 3, 2004, expires March 1, 2005. Amended: Filed Aug. 23, 2004.

PUBLIC COST: This proposed amendment will not cost state agencies or political subdivisions more than five hundred dollars (\$500) in the aggregate.

PRIVATE COST: This proposed amendment will not cost private entities more than five hundred dollars (\$500) in the aggregate.

NOTICE TO SUBMIT COMMENTS: Anyone may file a statement in support of or in opposition to this proposed amendment with the Division of Animal Health, PO Box 630, Jefferson City, MO 65102 or via e-mail at Taylor.Woods@mda.mo.gov. To be considered, comments must be received within thirty (30) days after publication of this notice in the Missouri Register. No public hearing is scheduled.

Title 2—DEPARTMENT OF AGRICULTURE
Division 30—Animal Health
Chapter 6—Livestock Markets

PROPOSED AMENDMENT

2 CSR 30-6.020 Duties and Facilities of the Market/Sale Veterinarian. The division is proposing to amend subsection (8)(D).

PURPOSE: This proposed amendment addresses the financial crisis affecting Missouri white-tail deer farmers due to the importation restriction implemented during the first years of chronic wasting disease (CWD) control and eradication efforts throughout the nation by reducing the required level of surveillance for CWD in order for white-tail deer to enter Missouri.

(8) Miscellaneous and Exotic Animals. All exotic animals presented for exchange, barter, lease or sale at a licensed livestock market/sale must be accompanied by an official Certificate of Veterinary Inspection showing an individual listing of the common and scientific name(s) of the animal(s) and appropriate descriptions of animal(s) such as sex, age, weight, coloration and the permanent tag number, brand or tattoo identification.

(D) Captive cervids from out-of-state that arrive at a market/sale in Missouri must have an entry permit issued by the state veterinarian's office and a Certificate of Veterinary Inspection. Captive cervids from out-of-state that arrive at a market/sale must be in compliance with the guidelines as incorporated by reference to the *Bovine Tuberculosis Eradication Uniform Methods and Rules, Effective January 22, 1999* and *Brucellosis in Cervidae: Uniform Methods and Rules, Effective September 30, 1998*. Movement of Missouri origin captive cervids must be in compliance with Missouri's intrastate movement regulations.

1. All sexually intact animals six (6) months of age or older, not under quarantine and not affected with brucellosis, must test negative for brucellosis within thirty (30) days prior to arrival at the market/sale, except:

A. Brucellosis-free herd—captive cervids originating from certified brucellosis-free herds may be sold through a market/sale on the current herd number and test date;

B. Brucellosis-monitored herd—all sexually intact animals six (6) months of age or older must test negative for brucellosis within ninety (90) days prior to arrival at the market/sale.

2. Captive cervids not known to be affected with or exposed to tuberculosis and not in a status herd, as defined in the *Bovine Tuberculosis Eradication Uniform Methods and Rules, Effective January 22, 1999*, must have two (2) negative tuberculosis tests, not less than ninety (90) days apart, using the single cervical method. The second test must be within ninety (90) days prior to arrival at the market/sale.

3. Movement from status herds.

A. Accredited herd—captive cervids originating from accredited tuberculosis-free cervid herd as defined by the *Bovine Tuberculosis Eradication Uniform Methods and Rules, Effective January 22, 1999*, may be sold through a market/sale on the current herd number and test date.

B. Qualified herd—captive cervids originating from a qualified herd as defined by the *Bovine Tuberculosis Eradication Uniform Methods and Rules, Effective January 22, 1999*, must have one (1) negative tuberculosis test, using the single cervical method, within ninety (90) days prior to arrival at the market/sale.

C. Monitored herd—captive cervids originating from a monitored herd as defined by the *Bovine Tuberculosis Eradication Uniform Methods and Rules, Effective January 22, 1999*, must have one (1) negative tuberculosis test, using the single cervical method, within ninety (90) days prior to arrival at the market/sale.

D. Captive cervids less than twelve (12) months of age that originate from and were born in qualified or monitored herds may be sold through a market/sale without further tuberculosis testing, provided that they are accompanied by a certificate stating that such captive cervids originated from such herds and have not been exposed to captive cervids from a lower status herd.

4. Captive cervids from an area that has been reported as a chronic wasting disease (CWD) endemic area or any cervid that has been in an endemic area in the last five (5) years will not be allowed to move through a Missouri livestock market/sale.

5. Elk, elk-hybrids [*white-tailed deer*] and mule deer from all states must have participated in a surveillance program for at least three (3) years prior to moving through a Missouri livestock market/sale. Other captive cervids other than white-tailed deer must have participated in a surveillance program recognized by the state of origin prior to moving through a Missouri livestock market/sale.

6. White-tailed deer from all states must have participated in a surveillance program for at least two (2) years prior to entering Missouri. Other captive cervids must have participated in a surveillance program recognized by the state of origin prior to entering Missouri.

7. All captive white-tailed deer that enter Missouri with a two (2)-year status in a CWD surveillance program and remain in Missouri at the time of death must be tested for CWD.

AUTHORITY: section 277.160, RSMo 2000. Original rule filed June 15, 1990. For intervening history, please consult the Code of State Regulations. Emergency amendment filed March 5, 2004, effective March 15, 2004, expires Aug. 27, 2004. Amended: Filed March 5, 2004. Emergency amendment filed Aug. 23, 2004, effective Sept. 3, 2004, expires March 1, 2005. Amended: Filed Aug. 23, 2004.

PUBLIC COST: This proposed amendment will not cost state agencies or political subdivisions more than five hundred dollars (\$500) in the aggregate.

PRIVATE COST: This proposed amendment will not cost private entities more than five hundred dollars (\$500) in the aggregate.

NOTICE TO SUBMIT COMMENTS: Anyone may file a statement in support of or in opposition to this proposed amendment with the Division of Animal Health, PO Box 630, Jefferson City, MO 65102 or via e-mail at Taylor.Woods@mda.mo.gov. To be considered, comments must be received within thirty (30) days after publication of this notice in the Missouri Register. No public hearing is scheduled.

**Title 2—DEPARTMENT OF AGRICULTURE
Division 70—Plant Industries
Chapter 40—Missouri Treated Timber Products Law
Rules**

PROPOSED AMENDMENT

2 CSR 70-40.015 Standards for Treated Timber. The director of agriculture is amending sections (1), (2), (3), and (4) to reference the 2004 American Wood Preservers Standards and deleting reference to the 2002 American Wood Preservers Standards.

PURPOSE: This amendment updates the required standards to be used by anyone selling or offering for sale treated timber products in the state of Missouri.

PUBLISHER'S NOTE: The secretary of state has determined that the publication of the entire text of the material which is incorporated by reference as a portion of this rule would be unduly cumbersome or expensive. This material as incorporated by reference in this rule shall be maintained by the agency at its headquarters and shall be made available to the public for inspection and copying at no more than the actual cost of reproduction. This note applies only to the reference material. The entire text of the rule is printed here.

(1) The preservatives and preservative solution used shall meet the American Wood Preservers' Association (AWPA) Standard P-Preservative, as published in the [2002] 2004 AWPA Book of Standards, as incorporated by reference in this rule. This material may be obtained by contacting the AWPA at PO Box 388, Selma, Alabama 36702-0388.

(2) Standards for Treatment of Coniferous, Softwood Species. The requirements for retention and penetration of preservatives used shall not be less than the published [2002] 2004 American Wood Preservers' Association Book of Standards, as incorporated by reference in this rule, except that—

(3) Standards for Treatment of Deciduous, Hardwood Species. The requirement for retention and penetration of preservatives used shall not be less than the published [2002] 2004 American Wood Preservers' Association Standards, as incorporated by reference in this rule, except that—

(4) Other Treatment Standards. All other standards for treatment of timber or timber products with preservatives not covered by 2 CSR 70-40.015 shall not be less than the published [2002] 2004 American Wood Preservers' Association Book of Standards, as incorporated by reference in this rule.

AUTHORITY: section 280.050, RSMo 2000. Original rule filed Oct. 10, 1980, effective Feb. 1, 1981. For intervening history, please consult the Code of State Regulations. Amended: Filed Aug. 30, 2004.

PUBLIC COST: This proposed amendment will not cost state agencies or political subdivisions more than five hundred dollars (\$500) in the aggregate.

PRIVATE COST: This proposed amendment will not cost private entities more than five hundred dollars (\$500) in the aggregate.

NOTICE TO SUBMIT COMMENTS: Anyone may file a statement in support of or in opposition to this proposed amendment with the Missouri Department of Agriculture, Forest Resources Program, Jimmy Williams, Program Coordinator, PO Box 630, Jefferson City, MO 65101. To be considered, comments must be received within thirty (30) days after publication of this notice in the Missouri Register. No public hearing is scheduled.

**Title 2—DEPARTMENT OF AGRICULTURE
Division 70—Plant Industries
Chapter 40—Missouri Treated Timber Products Law
Rules**

PROPOSED AMENDMENT

2 CSR 70-40.025 Standards For Inspection, Sampling and Analysis. The director of agriculture is amending sections (1), (2), and (3) to reference the 2004 American Wood Preservers Standards and deleting reference to the 2002 American Wood Preservers Standards.

PURPOSE: This amendment updates the required standards associated with the inspection, sampling and analysis of treated wood products.

PUBLISHER'S NOTE: The secretary of state has determined that the publication of the entire text of the material which is incorporated by reference as a portion of this rule would be unduly cumbersome or expensive. This material as incorporated by reference in this rule shall be maintained by the agency at its headquarters and shall be made available to the public for inspection and copying at no more than the actual cost of reproduction. This note applies only to the reference material. The entire text of the rule is printed here.

(1) The standards for inspection procedures shall be in accordance with the American Wood Preservers Association (AWPA) Standard M2-Inspection of Treated Timber Products as published in the [2002] 2004 AWPA Book of Standards, as incorporated by reference in this rule. This material may be obtained by contacting the AWPA at PO Box 388, Selma, Alabama 36702-0388.

(2) The standards for sampling and quality control procedures shall be in accordance with the published [2002] 2004 American Wood Preservers' Association, as incorporated by reference in this rule, except that—

(3) The standards for methods of analysis for all type preservatives used shall be in accordance with the American Wood Preservers' Association (AWPA) Standard A-Analysis Methods, as published in the [2002] 2004 AWPA Book of Standards, as incorporated by reference in this rule.

AUTHORITY: section 280.050, RSMo 2000. Original rule filed Oct. 10, 1980, effective Feb. 1, 1981. Amended: Filed Sept. 12, 1984, effective Jan. 1, 1985. Amended: Filed Dec. 16, 1985, effective March 13, 1986. Rescinded and readopted: Filed Aug. 6, 2002, effective March 30, 2003. Amended: Filed Aug. 30, 2004.

PUBLIC COST: This proposed amendment will not cost state agencies or political subdivisions more than five hundred dollars (\$500) in the aggregate.

PRIVATE COST: This proposed amendment will not cost private entities more than five hundred dollars (\$500) in the aggregate.

NOTICE TO SUBMIT COMMENTS: Anyone may file a statement in support of or in opposition to this proposed amendment with the Missouri Department of Agriculture, Forest Resources Program,

Jimmy Williams, Program Coordinator, PO Box 630, Jefferson City, MO 65101. To be considered, comments must be received within thirty (30) days after publication of this notice in the Missouri Register. No public hearing is scheduled.

Title 3—DEPARTMENT OF CONSERVATION
Division 10—Conservation Commission
Chapter 9—Wildlife Code: Confined Wildlife: Privileges, Permits, Standards

PROPOSED AMENDMENT

3 CSR 10-9.353 Privileges of Class I and Class II Wildlife Breeders. The commission proposes to amend sections (3), (4) and (18) and add a new section (13), and renumber sections accordingly.

PURPOSE: This amendment revises requirements for animal movement into Class I wildlife breeder facilities; allows nonresidents possessing legally acquired wildlife to exhibit such wildlife at special events without permit, not to exceed seven (7) consecutive days; requires exhibitors to meet confinement standards; prohibits sale or donation of captive wildlife; and changes wording for clarity.

(3) All elk, elk-hybrids, mule deer, and white-tailed deer, defined as Class I wildlife in 3 CSR 10-9.230, introduced into a Class I wildlife breeder operation shall meet the following requirements:

(A) Animals shall be tagged or marked in a method allowing **each individual animal [identification] to be uniquely identified.**

(B) Animals imported into Missouri must come from a herd that is enrolled and has achieved a status [~~three (3)~~] **two (2)** or higher in a United States Department of Agriculture approved or state-sponsored chronic wasting disease monitoring program—[~~three (3)~~] **two (2)** years of surveillance, advancement, and successful completion of program requirements.

(4) Effective January 1 of each year, one hundred percent (100%) of all elk, elk-hybrids, mule deer, and white-tailed deer, defined as Class I wildlife in 3 CSR 10-9.230, over twelve (12) months of age that die of any cause within a Class I wildlife breeder operation, shall be tested for chronic wasting disease at a federally approved laboratory, up to an annual total of ten (10) animals in the aggregate, except:

(A) **No testing is required for** Class I wildlife breeder operations that have not introduced, during the past three (3) years, any elk, elk-hybrids, mule deer or white-tailed deer from a herd having a status less than three (3) as documented through a United States Department of Agriculture approved or state-sponsored chronic wasting disease monitoring program—three (3) years of surveillance, advancement, and successful completion of program requirements.

(B) **No testing is required for** [E]elk, elk-hybrids, mule deer, and white-tailed deer documented through Missouri's [C]chronic [W]wasting [D]disease [M]monitoring [P]program as **from a status five (5) herd[s]—five (5) years of surveillance, advancement, and successful completion of program requirements.**

(C) **One hundred percent (100%) of all elk, elk-hybrids, mule deer and white-tailed deer that are imported into Missouri that are from a herd having a status less than three (3) as documented through a United States Department of Agriculture or state-sponsored chronic wasting disease monitoring program that die of any cause within a Class I wildlife breeder operation shall be tested for chronic wasting disease at a federally approved laboratory.**

(13) No Class I or Class II wildlife breeder permit is required for nonresidents possessing a valid permit issued in another state to exhibit legally possessed wildlife at special events, not to exceed seven (7) consecutive days; provided that:

(A) **Notification is made to an agent of the department prior to entry of wildlife into the state.**

(B) **Exhibited wildlife may not be sold, offered for sale, or given away.**

(C) **All other provisions of this chapter shall apply, including mobile temporary exhibit confinement standards as specified in 3 CSR 10-9.220.**

[(13)](14) None of these privileges shall extend to permitting the act of hunting for such stock except that big game mammals may be shot for purposes of herd management by the permit holder or his/her agents, but only by written authorization of the director.

[(14)](15) No state permit shall be required of individuals holding migratory waterfowl under valid federal authorization.

[(15)](16) No state permit shall be required for the propagation, sale or display of birds of prey by persons holding a valid federal permit; provided, that these birds may be used to take or attempt to take wildlife only by persons holding a valid falconry permit.

[(16)](17) The holder of a Class II wildlife breeder permit shall report escaped animals immediately to an agent of the department.

[(17)](18) The holder of a Class I wildlife breeder permit may sell legally[-] acquired **game bird eggs or** dressed or processed quail, pheasants, partridges [~~and game bird eggs~~] at retail and to commercial establishments under provisions of 3 CSR 10-10.743, provided all sales are accompanied by a valid invoice and the required records are maintained by the wildlife breeder.

[(18)](19) Animal health standards and movement activities shall comply with all state and federal regulations.

AUTHORITY: sections 40 and 45 of Art. IV, Mo. Const. This rule was previously filed as 3 CSR 10-10.755. Original rule filed Aug. 18, 1970, effective Dec. 31, 1970. For intervening history, please consult the Code of State Regulations. Amended: Filed Aug. 30, 2004.

PUBLIC COST: This proposed amendment will not cost state agencies or political subdivisions more than five hundred dollars (\$500) in the aggregate.

PRIVATE COST: This proposed amendment will not cost private entities more than five hundred dollars (\$500) in the aggregate.

NOTICE TO SUBMIT COMMENTS: Anyone may file a statement in support of or in opposition to this proposed amendment with John W. Smith, Deputy Director, Department of Conservation, PO Box 180, Jefferson City, MO 65102. To be considered, comments must be received within thirty (30) days after publication of this notice in the Missouri Register. No public hearing is scheduled.

Title 3—DEPARTMENT OF CONSERVATION
Division 10—Conservation Commission
Chapter 9—Wildlife Code: Confined Wildlife: Privileges, Permits, Standards

PROPOSED AMENDMENT

3 CSR 10-9.565 Licensed Hunting Preserve: Privileges. The commission proposes to amend subsection (1)(B).

PURPOSE: This amendment revises requirements for animal movement into big game hunting preserves.

(1) Licensed hunting [~~perserves~~] **preserves** are subject to inspection by an agent of the department at any reasonable time. Animal health

standards and movement activities shall comply with all state and federal regulations. Any person holding a licensed hunting preserve permit may release on his/her licensed hunting preserve legally acquired pheasants, exotic partridges, quail and ungulates (hoofed animals) for shooting throughout the year, under the following conditions:

(B) Big Game Hunting Preserve.

1. The big game hunting preserve for ungulates shall be a fenced single body of land, not dissected by public roads, and not less than three hundred twenty (320) acres and no more than three thousand two hundred (3,200) acres in size. The hunting preserve shall be fenced so as to enclose and contain all released game and exclude all hoofed wildlife of the state from becoming a part of the enterprise and posted with signs specified by the department. Fence height shall meet standards specified in 3 CSR 10-9.220.

2. All elk, elk-hybrids, mule deer, and white-tailed deer introduced into a big game hunting preserve shall meet the following requirements:

A. Animals shall be tagged or marked in a method allowing each individual animal [identification] to be uniquely identified.

B. Animals imported into Missouri must come from a herd that is enrolled and has achieved a status [three (3)] two (2) or higher in a United States Department of Agriculture approved or state-sponsored chronic wasting disease monitoring program—[three (3)] two (2) years of surveillance, advancement, and successful completion of program requirements.

C. Animals from within Missouri must come from a herd comprised of animals enrolled in a United States Department of Agriculture approved or state-sponsored chronic wasting disease monitoring program.

3. Effective January 1 of each year, one hundred percent (100%) of all elk, elk-hybrids, mule deer, and white-tailed deer over twelve (12) months of age that die of any cause within a big game hunting preserve operation, shall be tested for chronic wasting disease at a federally approved laboratory, up to an annual total of ten (10) animals in the aggregate, except:

A. No testing is required for [B]big game hunting preserve operations that have not introduced, during the past three (3) years, any elk, elk-hybrids, mule deer or white-tailed deer from a herd having a status less than three (3) as documented through a United States Department of Agriculture approved or state-sponsored chronic wasting disease monitoring program—three (3) years of surveillance, advancement, and successful completion of program requirements.

B. No testing is required for [E]elk, elk-hybrids, mule deer, and white-tailed deer documented through Missouri's [C]chronic [W]wasting [D]disease [M]monitoring [P]program as from a status five (5) herd/s—five (5) years of surveillance, advancement, and successful completion of program requirements.

C. One hundred percent (100%) of all elk, elk-hybrids, mule deer and white-tailed deer that are imported into Missouri that are from a herd having a status less than three (3) as documented through a United States Department of Agriculture or state-sponsored chronic wasting disease monitoring program that die of any cause within a big game hunting preserve shall be tested for chronic wasting disease at a federally approved laboratory.

4. All permits issued by the state veterinarian's office allowing cervids to enter Missouri and all chronic wasting disease test results must be kept by the permittee and are subject to inspection by an agent of the department at any reasonable time. All test results documenting a positive case of chronic wasting disease shall be reported immediately to an agent of the department.

5. The permittee may exercise privileges provided in 3 CSR 10-9.353 only for species held within breeding enclosure(s) contained within or directly adjacent to the big game hunting preserve. Any such breeding enclosure(s) shall meet standards specified in 3 CSR 10-9.220. Breeding enclosures may be separated from the hunting preserve by a public road, but must be directly adjacent. Other

breeding enclosures not contained within or directly adjacent to the hunting preserve are not covered under the privileges of this rule.

6. Any person taking or hunting ungulates on a big game hunting preserve shall have in his/her possession a valid licensed hunting preserve hunting permit. The permittee shall attach to the leg of each ungulate taken on the hunting preserve a locking leg seal furnished by the department, for which the permittee shall pay ten dollars (\$10) per one hundred (100) seals. Any packaged or processed meat shall be labeled with the licensed hunting preserve permit number.

7. Animal health standards and movement activities shall comply with all state and federal regulations.

AUTHORITY: sections 40 and 45 of Art. IV, Mo. Const. This rule previously filed as 3 CSR 10-10.765. Original rule filed Jan. 19, 1972, effective Feb. 1, 1972. For intervening history, please consult the Code of State Regulations. Amended: Filed Aug. 30, 2004.

PUBLIC COST: This proposed amendment will not cost state agencies or political subdivisions more than five hundred dollars (\$500) in the aggregate.

PRIVATE COST: This proposed amendment will not cost private entities more than five hundred dollars (\$500) in the aggregate.

NOTICE TO SUBMIT COMMENTS: Anyone may file a statement in support of or in opposition to this proposed amendment with John W. Smith, Deputy Director, Department of Conservation, PO Box 180, Jefferson City, MO 65102. To be considered, comments must be received within thirty (30) days after publication of this notice in the Missouri Register. No public hearing is scheduled.

**Title 4—DEPARTMENT OF ECONOMIC
DEVELOPMENT
Division 45—Athlete Agents
Chapter 1—General Rules**

PROPOSED RULE

4 CSR 45-1.010 Fees

PURPOSE: This rule outlines the various fees charged as authorized by sections 436.218–436.272 and as amended by SB 1122 2004.

- | | |
|------------------------|---------------------------------------|
| (1) Application Fee | \$500 |
| (2) Fingerprinting Fee | (As determined by the Highway Patrol) |

AUTHORITY: sections 436.227, 436.218 and 436.239 as amended by SB 1122 2004. Emergency rule filed Aug. 30, 2004, effective Sept. 9, 2004, expires March 7, 2005. Original rule filed Aug. 18, 2004.

PUBLIC COST: This proposed rule is estimated to cost state agencies and political subdivisions approximately seven thousand one hundred eighty-one dollars and eighty-five cents (\$7,181.85) annually for the life of the rule.

PRIVATE COST: This proposed rule is estimated to cost private entities approximately twenty-nine thousand ninety-one dollars and ninety-six cents (\$29,091.96) annually for the life of the rule.

NOTICE TO SUBMIT COMMENTS: Anyone may file a statement in support of or in opposition to this proposed rule with the Division of Professional Registration, ATTN: Tim Lueckenhoff, PO Box 1335, Jefferson City, MO 65102. To be considered, comments must be received within thirty (30) days after publication of this notice in the Missouri Register. No public hearing is scheduled.

PUBLIC ENTITY FISCAL NOTE

I. RULE NUMBER

Title 4 - Department of Economic Development

Division 45 - Athlete Agents

Chapter 1 - General Rules

Proposed Rule - 4 CSR 45-1.010 Fees

Prepared August 27, 2004 by the Division of Professional Registration

II. SUMMARY OF FISCAL IMPACT

| Affected Agency or Political Subdivision | Estimated Cost of Compliance |
|---|------------------------------|
| Division of Professional Registration | \$7,181.85 |
| Estimated Annual Cost of Compliance for the Life of the Rule | \$7,181.85 |

1. CALCULATION OF EXPENSE AND EQUIPMENT AND PERSONAL SERVICE COSTS:

Employee's salaries were calculated using their annual salary multiplied by 43.78% for fringe benefits and then were divided by 2080 hours per year to determine the hourly salary. The cost per hour was then multiplied by the amount of time individual staff spent processing the applications or renewals. The total cost was based on the cost per application multiplied by the estimated number of applications or renewals.

The figures below represent the personal service costs supported by the Division of Professional Registration. Staff duties include:

The Executive Director will devote 156 hours annually to reviewing applications with discrepancies and approving applications.

The Licensure Technician will devote 156 hours a year annually responding to telephone inquiries and written correspondence, mailing application packets and processing applications.

RENEWING AN EXPIRED LICENSE

| STAFF | ANNUAL SALARY | SALARY TO INCLUDE FRINGE BENEFIT | HOURLY SALARY | NUMBER OF HOURS PERFORMING DUTIES | TOTAL COST PER APPLICATION/RENEWAL |
|---------------------------------|---------------|----------------------------------|---------------|-----------------------------------|------------------------------------|
| Executive Director | \$42,756.00 | \$61,474.58 | \$29.56 | 156 | \$4,610.59 |
| Senior Office Support Assistant | \$23,376.00 | \$32,836.27 | \$15.79 | 156 | \$2,462.72 |

Total Annual Personal Service Cost \$7,073.31

Summary of Personal Service Expenses

Employee's Salaries \$7,073.31
Total Personal Service Expenses \$7,073.31

EXPENSE AND EQUIPMENT - RENEWING AN EXPIRED LICENSE

Envelope for Mailing Renewal Application \$0.16
 Postage for Mailing Renewal Application \$1.06
 Envelope for Mailing Application \$0.06
 Printing License \$0.35
 Envelope for Mailing License \$0.03
 Postage for Mailing License \$0.35
Total Expense and Equipment Cost: \$2.01

Total Expense and Equipment Expenses \$108.54

1. The division obtained the estimated number of licensees from the Secretary of State Office.
2. The total annual cost will recur for the life of the rule, may vary with inflation and is expected to increase at the rate projected by the Legislative Oversight Committee.

NOTE: The public fiscal note for this rule only reflects the cost for this particular process. However, private entity fees are set at an amount to cover the total actual cost incurred by the board, which includes personal service, expense and equipment and transfers.

PRIVATE ENTITY FISCAL NOTE

I. RULE NUMBER

Title 4 -Department of Economic Development

Division 45 - Athlete Agents

Chapter 1 - General Rules

Proposed Rule - 4 CSR 45-1.010 Fees

Prepared August 17, 2004 by the Division of Professional Registration

II. SUMMARY OF FISCAL IMPACT

Annual Cost to Comply Beginning in FY04

| Estimate the number of entities by class which would likely be affected by the adoption of the proposed amendment: | Classification by type of the business entities which would likely be affected: | Estimated annual cost of compliance with the amendment by affected entities: |
|--|---|--|
| 54 | Athlete Agents (application fee - \$500) | \$27,000.00 |
| 54 | Athlete Agents (fingerprinting fee - \$38) | \$2,052.00 |
| 54 | Athlete Agents (postage - \$.74) | \$39.96 |
| Estimated Annual Cost of Compliance for the Life of the Rule | | \$29,091.96 |

III. WORKSHEET

See table above.

IV. ASSUMPTION

1. The division obtained the estimated number of licensees from the Secretary of State Office.
2. Applicants are required to submit a photograph as part of the application process. The cost for the photograph was not included in the private entity fiscal note as the division assumes applicants will not have additional cost if they submit a recent snap shot.
3. The Missouri Highway Patrol establishes the background check fee, therefore, applicants may incur a variance in cost should those fees be increased or decreased.
4. The total annual cost will recur for the life of the rule, may vary with inflation and is expected to increase at the rate projected by the Legislative Oversight Committee.

NOTE: The board is statutorily obligated to enforce and administer the provisions of sections 436.227-426.272, RSMo. Pursuant to section 436.239, RSMo, the board shall by rule and regulation set the amount of fees authorized by section 436.239, RSMo so that the revenue produced is sufficient, but not excessive, to cover the cost and expense to the board for administering the provisions of section 436.239, RSMo, RSMo. This proposed amendment is necessary because the board's projected revenue will not support the expenditures necessary to enforce and administer the provisions of sections 436.227-426.272, RSMo, which will result in an endangerment to the health, welfare, and safety of the public.

**Title 4—DEPARTMENT OF ECONOMIC
DEVELOPMENT**

**Division 230—State Board of Podiatric Medicine
Chapter 1—Organization and Description of Board**

PROPOSED AMENDMENT

4 CSR 230-1.010 General Organization. The board is proposing to amend sections (3), (4), (5), (6) and (8).

PURPOSE: This rule is being amended to make the text of the rule consistent with terminology currently used by the board.

(3) The board consists of four (4) **Missouri**-licensed doctors of *[podiatry]* **podiatric medicine** and one (1) public member. The governor appoints the members of the board with the advice and consent of the senate, from nominees submitted by the director of the Department of Economic Development. The term of office of each member is four (4) years.

(4) The board is authorized by section 330.140[.1.], RSMo [1986] to adopt rules necessary to administer and enforce the provisions of Chapter 330, RSMo.

(5) The board has superintending control over the practice of *[podiatry]* **podiatric medicine** within this state. The board's primary duties consist of—

(B) Approving colleges of *[podiatry]* **podiatric medicine**;

(E) *[Suspending or revoking]* **Disciplining** licenses of doctors found guilty of violating the provisions of Chapter 330, RSMo.

(6) The board shall have at least one (1) regularly scheduled annual meeting and such other meetings as determined by the board. The time and location for each meeting may be obtained by contacting the *[board's executive secretary]* **board office** at P[.JO[.] Box 423, Jefferson City, MO 65102-0423 or by visiting the board's website at <http://pr.mo.gov/podiatrists.asp>.

(8) Members of the public may obtain information from the board or make submissions to the board, by writing the *[board's executive secretary]* **board office** at P[.JO[.] Box 423, Jefferson City, MO 65102-0423 or by visiting the board's website at <http://pr.mo.gov/podiatrists.asp>.

AUTHORITY: sections 330.140[.1] and 536.023.3, RSMo [Cum. Supp. 1997] 2000. Original rule filed Dec. 23, 1975, effective Jan. 2, 1976. Rescinded and readopted: Filed Dec. 9, 1981, effective March 11, 1982. Amended: Filed Oct. 30, 1997, effective April 30, 1998. Amended: Filed Sept. 1, 2004.

PUBLIC COST: This proposed amendment will not cost state agencies or political subdivisions more than five hundred dollars (\$500) in the aggregate.

PRIVATE COST: This proposed amendment will not cost private entities more than five hundred dollars (\$500) in the aggregate.

NOTICE TO SUBMIT COMMENTS: Anyone may file a statement in support of or in opposition to this proposed amendment with the Missouri State Board of Podiatric Medicine, PO Box 423, Jefferson City, MO 65102, by facsimile to (573) 751-1155 or by e-mail to podiatry@pr.mo.gov. To be considered, comments must be received within thirty (30) days after publication of this notice in the Missouri Register. No public hearing is scheduled.

**Title 4—DEPARTMENT OF ECONOMIC
DEVELOPMENT**

**Division 230—State Board of Podiatric Medicine
Chapter 1—Organization and Description of Board**

PROPOSED AMENDMENT

4 CSR 230-1.020 Board Member Compensation. The board is proposing to amend the Purpose statement.

PURPOSE: This rule is being amended to make the Purpose statement consistent with terminology currently used by the board.

PURPOSE: This rule fixes the compensation for the members of the State Board of [Podiatry] Podiatric Medicine in compliance with the mandates of section 330.110.1, RSMo [1986].

AUTHORITY: sections 330.110 and 330.140[.1], RSMo [Cum. Supp. 1997] 2000. Emergency rule filed Sept. 17, 1981, effective Sept. 28, 1981, expired Dec. 28, 1981. Original rule filed Sept. 17, 1981, effective Jan. 14, 1982. Amended: Filed Oct. 30, 1997, effective April 30, 1998. Amended: Filed Sept. 1, 2004.

PUBLIC COST: This proposed amendment will not cost state agencies or political subdivisions more than five hundred dollars (\$500) in the aggregate.

PRIVATE COST: This proposed amendment will not cost private entities more than five hundred dollars (\$500) in the aggregate.

NOTICE TO SUBMIT COMMENTS: Anyone may file a statement in support of or in opposition to this proposed amendment with the Missouri State Board of Podiatric Medicine, PO Box 423, Jefferson City, MO 65102, by facsimile to (573) 751-1155 or by e-mail to podiatry@pr.mo.gov. To be considered, comments must be received within thirty (30) days after publication of this notice in the Missouri Register. No public hearing is scheduled.

**Title 4—DEPARTMENT OF ECONOMIC
DEVELOPMENT**

**Division 230—State Board of Podiatric Medicine
Chapter 1—Organization and Description of Board**

PROPOSED RULE

4 CSR 230-1.030 Definitions

PURPOSE: This rule defines terms used in 4 CSR 230.

(1) Board—whenever used in these rules, unless stated otherwise, the term board means the State Board of Podiatric Medicine in the state of Missouri.

(2) Certificate of Registration—as referred to in Chapter 330, RSMo and these rules means license to practice podiatric medicine in the state of Missouri.

(3) Postgraduate clinical residency—a formal, structured postgraduate training program of at least twelve (12) months which is approved by the Council on Podiatric Medical Education of the American Podiatric Medical Association. Postgraduate clinical residency programs must be sponsored by and conducted in an institution such as a hospital, or conducted by a college of podiatric medicine accredited by the Council on Podiatric Medical Education of the American Podiatric Medical Association.

(4) Missouri Law Examination—Missouri Law Examination covers knowledge of Chapter 330, RSMo and the rules governing the practice of podiatric medicine in the state of Missouri.

(5) National Board Examination—Part 1, Part 2, Part 3 (formally known as the Podiatric Medical Licensing Examination for States,

PMLexis) developed and administered by the National Board of Podiatric Medical Examiners (NBPME), or designee of the board.

(6) Reporting period for Continuing Medical Education requirements—the twenty-four (24)-month period immediately preceding the biennial licensure renewal date, which is February 28 of each even-numbered year.

AUTHORITY: sections 330.010, 330.040, 330.050, 330.070 and 330.140, RSMo 2000. Original rule filed Sept. 1, 2004.

PUBLIC COST: This proposed rule will not cost state agencies or political subdivisions more than five hundred dollars (\$500) in the aggregate.

PRIVATE COST: This proposed rule will not cost private entities more than five hundred dollars (\$500) in the aggregate.

NOTICE TO SUBMIT COMMENTS: Anyone may file a statement in support of or in opposition to this proposed rule with the Missouri State Board of Podiatric Medicine, PO Box 423, Jefferson City, MO 65102, by facsimile to (573) 751-1155 or by e-mail to podiatry@pr.mo.gov. To be considered, comments must be received within thirty (30) days after publication of this notice in the *Missouri Register*. No public hearing is scheduled.

**Title 4—DEPARTMENT OF ECONOMIC
DEVELOPMENT
Division 230—State Board of Podiatric Medicine
Chapter 2—General Rules**

PROPOSED AMENDMENT

4 CSR 230-2.010 Application for Licensure by Examination. The board is proposing to amend sections (1) and (10); add new sections (2), (3), (8), (9) and (11); renumber and amend the previously numbered sections (2), (3) (4) and (5); delete the previously numbered sections (6), (7), (8) and (11); and delete section (12).

PURPOSE: This rule is being amended to clarify the procedures to be used to secure a licensure.

(1) Application/s/ for a permanent Missouri license to practice [podiatry] **podiatric medicine** must be made on the forms provided by the board.

(2) Application forms may be obtained from the board office at PO Box 423, Jefferson City, MO 65102-0423 or by visiting the board's website at <http://pr.mo.gov/podiatrists.asp>. A copy of the current statutory provisions and board rules regarding the practice of podiatric medicine will be provided with the application form.

(3) No application will be considered unless it is fully completed and properly attested. Items necessary to complete the application include:

- (A) Each section on the application form itself;
- (B) A recent photograph;
- (C) The current Permanent Application Processing Fee;
- (D) An official transcript from the college of podiatric medicine from which the applicant graduated. If the applicant has attended more than one college of podiatric medicine in order to obtain all of his/her credits for graduation, the applicant shall submit official transcripts from all colleges s/he attended; and
- (E) A certified score report from the National Board of Podiatric Medical Examiners or such other designee of the board, certifying satisfactory completion of all parts of the National Board Examination.

[[2]] (4) Every applicant for a permanent Missouri license graduating from a podiatric medical school in 1994 and thereafter [that] shall provide the State Board of [Podiatry] **Podiatric Medicine** with satisfactory evidence of having completed an acceptable postgraduate clinical residency.

[[3]] (5) For purposes of this rule, a **postgraduate** clinical residency is a formal, structured [postdoctoral] **postgraduate** training program of at least twelve (12) months, which is approved by the Council on Podiatric Medical Education of the American Podiatric Medical Association. **Postgraduate** /C/clinical residency programs must be sponsored by and conducted in an institution such as a hospital, or conducted by a college of podiatric medicine accredited by the Council on Podiatric Medical Education of the American Podiatric Medical Association.

[[4]] (6) [Effective January 1, 2005, all a] Applicants desiring to perform ankle surgery will be required to complete a twenty-four (24)-month **postgraduate clinical** residency in podiatric surgery.

[[5]] (7) All applicants must be evaluated upon completion of [the] **at least a twelve (12)-month postgraduate clinical** residency program by the residency director, using forms provided by the board, which will attest to the [candidate's] **applicant's** competence in the practice of podiatric medicine and surgery.

[[6]] Upon completion of the residency program, all candidates must satisfy the board that s/he has not been the subject of disciplinary action concerning professional conduct or practice and meet other requirements as may be established by the board.

(7) Application forms may be obtained from the board's executive director at P.O. Box 423, Jefferson City, MO 65102-0423. A copy of the current statutory provisions and board rules regarding the practice of podiatry will be provided with the application form.

(8) No application for examination will be considered unless it is fully completed and properly attested. Items necessary to complete the application include:

- (A) Each section on the application form itself;
- (B) A recent unmounted photograph two and one-fourth inches by two and one-fourth inches (2 1/4" × 2 1/4");
- (C) The current examination fee and application fee;
- (D) An official transcript from a college of podiatric medicine;
- (E) A certified score report from the National Board of Podiatry Examiners; and
- (F) A copy of the applicant's diploma evidencing graduation from an approved college of podiatry no larger than six inches by eight inches (6" × 8").

(9) Applications must be received by the board's executive director no later than thirty (30) days prior to the examination. Applications received or completed less than thirty (30) days before the next scheduled examination will not be considered for that examination, but will be considered for the following examination.]

(8) The applicant shall request that the regulatory entity in each state, United States territory, province, or country in which a license, certificate, registration or permit is held or has ever been held submit verification of licensure, certification, registration or permit directly to the board. The verification shall include the license, registration, certification or permit issued; the number; status; issue and expiration dates; information regarding any disciplinary action; method of licensure, registration or certification; the name and title of person verifying information; the date; and the entity's seal.

(9) For every person desiring to enter the profession of podiatric medicine within Missouri, the board shall conduct a criminal history background check through the Missouri State Highway Patrol. Applicants shall submit to the board the applicable fee for the criminal history background check as determined by the Missouri State Highway Patrol.

(10) [Each applicant must successfully complete the examination administered by the National Board of Podiatric Medical Examiners (N.B.P.M.E.). In addition, each applicant must successfully complete the examination administered by the board. Beginning with the examination to be administered in December 1989, the board will administer the national board's podiatric medical licensure examination for states, the PMLexis and an examination on Missouri law. The Missouri board recognizes applicants who passed the Virginia Licensing Examination in 1985 and through 1988 or the PMLexis in 1988 or later as fulfilling the requirement of passing the PMLexis. The Missouri board will recognize the standards for passage of either examination based on the standards established by the state administering the examination. Only those applicants achieving a passing score as established by the N.B.P.M.E. on the PMLexis administered by the Missouri board, and achieving at least ninety percent (90%) on the open book test on Missouri law, shall be deemed to have passed the board's examination.] Each applicant must successfully complete the examination(s) developed and administered by the National Board of Podiatric Medical Examiners (NBPME) or such other designee of the board and successfully complete the Missouri Law Examination administered by the State Board of Podiatric Medicine. The applicants achieving a passing score as established by NBPME or such other designee of the board on the National Board Examinations and achieving at least ninety percent (90%) on the open book test for the Missouri Law Examination, shall be deemed to have passed the board's examination. The applicant will be required to pay the Missouri Law Examination Administration Fee directly to the board office. The NBPME examinations are computer-based examinations. The National Board Examinations are administered by the Chauncey Group International for the NBPME, or such other designee of the board. Applicants must submit a completed registration form along with the test fee and school transcript directly to the Chauncey Group or designee of the board.

(11) [All examinations will be conducted in the English language.] An applicant approved for licensure will be required to pay the applicable licensure fee.

[(12) No private examinations will be conducted by the board.]

AUTHORITY: sections 330.010[.1], 330.040 and 330.140[.1], [RSMo Supp. 1998 and 330.040,] RSMo [1994] 2000. Original rule filed Dec. 23, 1975, effective Jan. 2, 1976. For intervening history, please consult the *Code of State Regulations*. Amended: Filed Sept. 1, 2004.

PUBLIC COST: This proposed amendment will not cost state agencies or political subdivisions more than five hundred dollars (\$500) in the aggregate.

PRIVATE COST: This proposed amendment will not cost private entities more than five hundred dollars (\$500) in the aggregate.

NOTICE TO SUBMIT COMMENTS: Anyone may file a statement in support of or in opposition to this proposed amendment with the Missouri State Board of Podiatric Medicine, PO Box 423, Jefferson City, MO 65102, by facsimile to (573) 751-1155 or by e-mail to

podiatry@pr.mo.gov. To be considered, comments must be received within thirty (30) days after publication of this notice in the *Missouri Register*. No public hearing is scheduled.

**Title 4—DEPARTMENT OF ECONOMIC
DEVELOPMENT
Division 230—State Board of Podiatric Medicine
Chapter 2—General Rules**

PROPOSED AMENDMENT

4 CSR 230-2.020 Professional Conduct Rules. The board is proposing to amend sections (1) and (2) and to delete the annotations that immediately follow this rule in the *Code of State Regulations*.

PURPOSE: The board is proposing to delete the annotations that immediately follow this rule in the *Code of State Regulations*, and to make the text of the rule consistent with terminology currently used by the board.

(1) It will be considered dishonesty in the practice of [podiatry] podiatric medicine for a licensed podiatrist to use a trade name or assumed name in connection with his/her practice, unless the name of the podiatrist using that trade name or assumed name also appears along with the trade or assumed name.

(2) Nothing in section (1) of this rule will be construed to prohibit practice by a partnership of podiatrists under an assumed name or trade name, or the practice of [podiatry] podiatric medicine under a legally-formed professional corporation; provided, however, that where this partnership uses an assumed or trade name in connection with its practice, all of the names of the podiatrists who are partners in the partnership must appear along with the trade or assumed name, provided further, that where a professional corporation uses an assumed or trade name in connection with a practice, the name of each shareholder in the professional corporation must appear along with the trade or assumed name.

AUTHORITY: sections 330.140[.1] and 330.160.2(6), RSMo [1986] 2000. Original rule filed Dec. 23, 1975, effective Jan. 2, 1976. Rescinded and readopted: Filed Jan. 4, 1980, effective April 11, 1980. Rescinded and readopted: Filed Dec. 9, 1981, effective March 11, 1982. Amended: Filed Sept. 1, 2004.

PUBLIC COST: This proposed amendment will not cost state agencies or political subdivisions more than five hundred dollars (\$500) in the aggregate.

PRIVATE COST: This proposed amendment will not cost private entities more than five hundred dollars (\$500) in the aggregate.

NOTICE TO SUBMIT COMMENTS: Anyone may file a statement in support of or in opposition to this proposed amendment with the Missouri State Board of Podiatric Medicine, PO Box 423, Jefferson City, MO 65102, by facsimile to (573) 751-1155 or by e-mail to podiatry@pr.mo.gov. To be considered, comments must be received within thirty (30) days after publication of this notice in the *Missouri Register*. No public hearing is scheduled.

**Title 4—DEPARTMENT OF ECONOMIC
DEVELOPMENT
Division 230—State Board of Podiatric Medicine
Chapter 2—General Rules**

PROPOSED AMENDMENT

4 CSR 230-2.021 Advertising Regulation. The board is proposing to amend the Purpose statement and amend sections (3) and (6) and subsections (7)(A), (C), and (E).

PURPOSE: This rule is being amended to make the text of the rule consistent with terminology currently used by the board.

PURPOSE: This rule sets forth the content and methods [by which] that podiatrists who are licensed by the State Board of [Podiatry may] Podiatric Medicine shall follow if they advertise their services to the public in Missouri.

(3) Definitions. The following words and terms when used in this rule shall have the following meaning/s:

(A) *[The term a]*Advertisement shall mean any attempt, directly or indirectly, by publication, dissemination or circulation in print, or electronic media which, directly or indirectly, induces or attempts to induce any person or entity to purchase or enter into an agreement to purchase services, treatment or related goods from a podiatrist;

(B) *[The term e]*Electronic media shall include radio, *[and]* television, **e-mail and Internet**; *[and]*

(C) *[The term p]*Print media shall include, but not be limited to, newspapers, magazines, periodicals, professional journals, telephone directories, circulars, handbills, flyers, billboards, signs, matchcovers, **Internet, e-mail**, and other items, documents or comparable publications, the content of which is disseminated by means of the printed word;

(D) *[The term r]*Range of fees shall refer to an expressly stated upper and lower limit on the fees charged for services or goods offered by a podiatrist;

(E) *[The term s]*Solicitation shall mean any conduct other than that which has been defined as advertising which occurs outside the podiatrist's office and which, directly or indirectly, induces or attempts to induce any person or entity to purchase or enter into an agreement to purchase services, treatment or related goods from a podiatrist.

(6) Podiatrists may engage in solicitation, personally or through agents or representatives, except podiatrists *[may] shall not* advertise or solicit using—

(7) False, misleading or deceptive advertising or soliciting includes, but is not limited to, the following:

(A) Use of a trade name or assumed name in connection with a podiatrist's practice, unless the name of the podiatrist using that trade name or assumed name also appears along with the trade or assumed name. Nothing in this rule will be construed to prohibit practice by a partnership of podiatrists under an assumed name or trade name, or the practice of *[podiatry] podiatric medicine* under a legally formed professional corporation; provided, however, that where the partnership uses an assumed or trade name in connection with its practice, all of the names of the podiatrists who are partners in the partnership must appear along with the trade or assumed name; provided further, that where a professional corporation uses an assumed or trade name in connection with a practice, the name of each shareholder in the professional corporation must appear along with the trade or assumed name;

(C) Any offer of a professional service which the podiatrist knows or should know is beyond the podiatrist's ability to perform or *[which] that* is for any other reason not readily available;

(E) Any advertisement which fails to identify the podiatrist's profession by not including the word podiatrist, doctor of *[podiatry] podiatric medicine* or DPM following the podiatrist's name;

AUTHORITY: sections 330.140[.1.] and 330.160, RSMo [Supp. 1997] 2000. Original rule filed Oct. 15, 1985, effective Jan. 12, 1986. Amended: Filed Nov. 4, 1986, effective Jan. 30, 1987. Amended: Filed May 16, 1995, effective Dec. 30, 1995. Amended:

Filed Oct. 30, 1997, effective April 30, 1998. Amended: Filed Sept. 1, 2004.

PUBLIC COST: This proposed amendment will not cost state agencies or political subdivisions more than five hundred dollars (\$500) in the aggregate.

PRIVATE COST: This proposed amendment will not cost private entities more than five hundred dollars (\$500) in the aggregate.

NOTICE TO SUBMIT COMMENTS: Anyone may file a statement in support of or in opposition to this proposed amendment with the Missouri State Board of Podiatric Medicine, PO Box 423, Jefferson City, MO 65102, by facsimile to (573) 751-1155 or by e-mail to podiatry@pr.mo.gov. To be considered, comments must be received within thirty (30) days after publication of this notice in the Missouri Register. No public hearing is scheduled.

**Title 4—DEPARTMENT OF ECONOMIC
DEVELOPMENT
Division 230—State Board of Podiatric Medicine
Chapter 2—General Rules**

PROPOSED AMENDMENT

4 CSR 230-2.022 [Podiatry] Podiatric Titles. The board is proposing to amend the title, Purpose statement and section (1).

PURPOSE: This rule is being amended to make the text of the rule consistent with terminology currently used by the board.

PURPOSE: This rule clarifies that no person other than a licensed podiatrist may use the [podiatry] podiatric medical titles defined in this rule.

(1) Only persons who hold a license to practice *[podiatry] podiatric medicine* in this state may use the words **podiatric medicine**, podiatry, podiatric, podiatrist, foot specialist, chiropody or chiropodist, or variations of these words in connection with his/her practice. Any person who holds a license to practice *[podiatry] podiatric medicine* in this state may also use the abbreviation DPM in connection with his/her practice. No other person shall assume any title or use any abbreviation or other words including, but not limited to, the words and abbreviation listed in this rule, letters, signs or devices to indicate the person using the same is a licensed podiatrist.

AUTHORITY: sections 330.140[.1.] and 330.200, RSMo [1986] 2000. Original rule filed Aug. 11, 1992, effective Feb. 26, 1993. Amended: Filed Sept. 1, 2004.

PUBLIC COST: This proposed amendment will not cost state agencies or political subdivisions more than five hundred dollars (\$500) in the aggregate.

PRIVATE COST: This proposed amendment will not cost private entities more than five hundred dollars (\$500) in the aggregate.

NOTICE TO SUBMIT COMMENTS: Anyone may file a statement in support of or in opposition to this proposed amendment with the Missouri State Board of Podiatric Medicine, PO Box 423, Jefferson City, MO 65102, by facsimile to (573) 751-1155 or by e-mail to podiatry@pr.mo.gov. To be considered, comments must be received within thirty (30) days after publication of this notice in the Missouri Register. No public hearing is scheduled.

**Title 4—DEPARTMENT OF ECONOMIC
DEVELOPMENT
Division 230—State Board of Podiatric Medicine
Chapter 2—General Rules**

PROPOSED AMENDMENT

4 CSR 230-2.030 Biennial License Renewal. The board is proposing to amend sections (1)–(4); add new sections (5)–(9); and delete previously numbered sections (5)–(8).

PURPOSE: This rule is being amended to clarify the requirements and procedures for biennial license renewal. The board is also adding additional guidelines to govern the continuing medical education requirements.

(1) All Missouri podiatric physicians *[must]* shall notify the *[board's executive director]* board office of all offices, shared or individual; or changes in office addresses and designate at which address mail is to be received.

(2) Each applicant for *[licensure]* license renewal *[must provide a certificate of attendance for twelve (12)]* shall certify to the board that s/he has attended twenty-four (24) hours *[each year]* of board-approved continuing medical education (CME) for the biennial renewal period immediately preceding the biennial license renewal date. Applicants who qualify under section 330.010.2, RSMo *[Supp. 1996]* to perform surgery of the ankle must *[submit]* certify that s/he has attended an additional *[thirteen (13)]* twenty-six (26) hours *[each year of CME]* of board-approved CME for the biennial renewal period immediately preceding the biennial license renewal date. Prior to January 2005, *[A]* a copy of Foot & Ankle Board Certification or certificate of a *[two (2)-year]* twenty-four (24)-month postgraduate clinical residency program *[must]* in podiatric surgery shall be on file with the state board for acceptance of the additional CMEs, before *[an]* the endorsement of "Ankle Surgery Certified" will be added to their biennial renewal *[certificate]* license. After January 2005, a certificate of completion of a twenty-four (24)-month postgraduate clinical residency program in podiatric surgery is required for acceptance of the additional CMEs and the "Ankle Surgery Certified" endorsement.

(3) The reporting period for satisfying the CME requirements shall be *[January 1 through December 31 of each year preceding the year of licensure, beginning March 1. On or before January 1, of the year of licensure, each licensed podiatrist shall submit certificates of attendance for the appropriate number of CME hours which must be board approved. However, this requirement may be fulfilled by the CME sponsor submitting a list of all Missouri attendee(s) to the board. It is, ultimately, the licensee's responsibility to assure the board receives evidence of the CMEs. The certificate of attendance must indicate the date and place of the meeting, the number of approved CME hours, and must be signed by the sponsor's chairman or secretary. This should be mailed to P.O. Box 423, Jefferson City, MO 65102.]* the twenty-four (24)-month period immediately preceding the biennial license renewal date, which is February 28 of each even numbered year. All CME hours shall be board approved. CME hours earned after the biennial renewal date (February 28 of even-numbered years) shall apply to the next reporting cycle. A renewal license will not be issued until all renewal requirements have been met.

(4) *[Upon receipt of the appropriate number of CME hours (twelve (12) or twenty-five (25)) each year, the board will issue a receipt to confirm that the CME requirements have been met for that year.]* For the license renewal due on

February 28, 2006, and each subsequent renewal thereafter, the licensee shall certify that s/he has obtained at least twenty-four (24) or fifty (50) hours, whichever is relevant, of continuing medical education during the two (2)-year period preceding the renewal on the renewal form provided by the board. The renewal form shall be submitted directly to the board, either by mail or online renewal, by February 28 of each even-numbered year. The licensee shall not submit the record of CME attendance to the board except in the case of a board audit.

[(5) Educational programs that are currently approved by the board include:

(A) Educational programs approved by the American Podiatric Medical Association;

(B) Educational programs, appropriate to the practice of podiatry as approved by the board, presented by a hospital which is accredited by the Joint Commission on Hospital Accreditation or its equivalent; and

(C) For the first renewal of a podiatrist's license, the board will consider the successful completion of the PMLexis exam as satisfying the twelve (12) hours of continuing education of one (1) year required by this rule if the PMLexis exam was taken within the continuing education reporting period.

(6) Any other regularly organized group of podiatrists that wishes to sponsor an educational program to meet the standard for biennial license renewal in Missouri must submit one (1) copy of the program schedule, the outline, and the appropriate fee to the board's executive director not less than sixty (60) days prior to the date of the program. The outline must indicate the program's subject matter, the number of hours required for its presentation and the identity and qualifications of the speakers and instructors. After reviewing the schedule and outline, the board may grant approval. The board will also consider requests for approval of any meeting submitted after the meeting. When any continuing education program is attended which does not have current board approval and the sponsor has not submitted the outline, or the appropriate sponsor's fee, the individual attendee(s) may submit a copy of the program, evidence of attendance as specified in section (3) of this rule, and the appropriate sponsor's fee. If the program is approved by the board, the credit will be accepted and the licensee's record updated.

(7) Exception to the provisions of this rule is granted to those Registrants who are in training at a residency program approved by the Council of Podiatric Medical Education of the American Podiatric Medical Association. The residency program director must submit a letter to the board attesting that the resident is currently in good standing and indicating the date on which training is due to be completed.

(8) Applications for license renewal received in the board's office more than one (1) year, but less than five (5) years, after the renewal date will be renewed upon payment of the current renewal fee, applicable reactivation fee and upon providing satisfactory evidence of completing the continuing education requirements for each year. In addition, each applicant must successfully complete the reactivation examination administered by the board. No license will be renewed more than five (5) years after the renewal date. Complete reapplication is required.]

(5) Every licensee shall maintain full and complete records of all approved CME hours earned for the two (2) previous reporting periods in addition to the current reporting period. The records shall document the titles of the courses taken, dates, locations,

course sponsors, number of hours earned and certificate of attendance or completion. The board may conduct an audit of licensees to verify compliance with the continuing education requirements. Licensees shall assist the board in its audits by providing timely and complete responses to the board's inquiries.

(6) Violation of any provision of this rule shall be grounds for discipline in accordance with section 330.160, RSMo.

(7) The following guidelines govern the CME requirements needed to apply for biennial licensure renewal:

(A) Educational programs approved by the Council of Podiatric Medical Education of the American Podiatric Medical Association are currently approved by the board.

(B) The board will review for consideration of CME credits, the following postgraduate study to meet the standards for biennial license renewal. The licensee shall submit a copy of the program schedule, the outline, and the appropriate Continuing Education Board Review Fee to the board office not less than sixty (60) days prior to the date of the program. The outline must indicate the program's subject matter, the number of hours required for its presentation and the identity and qualifications of the speakers and instructors. After reviewing the schedule and outline, the board may grant approval. If the board approves the program, the credit will be accepted and the licensee may count the CME hours toward the total number of required hours. If the postgraduate study request is submitted after the sixty (60)-day deadline, payment of the Continuing Medical Education Reporting Period Late Fee will be required. The following programs may be reviewed by the board for CME credit:

1. Educational programs, appropriate to the practice of podiatric medicine, presented by:

A. A hospital accredited by the Joint Commission on Hospital Accreditation;

B. American Medical Association (AMA); or

C. American Osteopathic Association (AOA) or its equivalent.

2. Meetings. Registered attendance at relevant podiatric medicine related professional meetings (international, national, regional, state or local). CME credits may be granted for no more than four (4) hours per day for professional meeting attendance.

3. Presenting or speaking at a formal professional meeting in the area of podiatric medicine or a related field. CME credits may be granted at the rate of four (4) hours for each presentation. No CME credit based on the same presentation will be allowed for use in the subsequent two (2)-year reporting period.

4. Writing a paper published in a professional journal, writing an original chapter in a book or an edited book, or for editing or writing a book, in the area of podiatric medicine or a related field. Credits may be granted for the year of publication or presentation. CME credits may be granted at the rate of four (4) hours for each paper, eight (8) hours for each chapter in a book, ten (10) hours for editing a book, and fifteen (15) hours for the publication of a book. No CME credit based on the same materials will be allowed for use in the subsequent two (2)-year reporting period.

(C) Licensees who attend the open session of the Missouri State Board of Podiatric Medicine's board meetings will receive one (1) hour of CME credit per meeting. To qualify, licensees must sign in at the beginning of the open meeting and sign out at the end of the open meeting.

(D) Licensees who give presentations in accordance with this rule will receive up to two (2) CME credit hours for each hour of the original presentation and an hour-for-hour credit for subsequent presentation of the same material for a total of up to six (6) hours per each two (2)-year reporting period for licensees who are required to obtain twenty-four (24) hours of CME credit, or

a total of up to twelve (12) hours per each two (2)-year reporting period for licensees who are required to obtain fifty (50) hours of CME credit.

(E) Licensees who are required to obtain twenty-four (24) hours of CME credit in a two (2)-year reporting period may use up to six (6) hours of self-study CME credit in each reporting period, in accordance with this rule. Licensees who are required to obtain fifty (50) hours of CME credit in a two (2)-year reporting period may use up to twelve (12) hours of self-study CME credit in each reporting period, in accordance with this rule.

(F) Licensees who are required to obtain twenty-four (24) hours of CME credit in a two (2)-year reporting period may carry over up to six (6) CME credit hours earned in excess of the required twenty-four (24) hours to the next two (2)-year reporting period. Licensees who are required to obtain fifty (50) hours of CME credit in a two (2)-year reporting period may carry over up to twelve (12) CME credit hours earned in excess of the required fifty (50) hours to the next two (2)-year reporting period.

(G) An applicant who has not satisfied the CME requirements in accordance with this rule shall be required to meet the CME requirements retroactively as well as pay the required Continuing Medical Education Reporting Period Late Fee.

(H) Exceptions to the provisions of this rule include the following:

1. Licensees who were in training at least a minimum of six (6) months during the CME reporting period at a residency program approved by the Council of Podiatric Medical Education of the American Podiatric Medical Association are exempt from obtaining the required CME hours for the continuing medical education reporting period that the licensee was in the residency program. The residency program director must complete the form provided by the board, attesting that the applicant has attended an approved postgraduate clinical residency program for not less than six (6) months during the twenty-four (24)-month continuing medical education renewal reporting period. The certificate must indicate that the applicant was in good standing and indicate the dates of attendance during the postgraduate clinical residency program. The licensee shall maintain this certificate in his/her records of CME attendance.

2. For the first renewal of a podiatrist's license, the board will consider the passing score of the national board (Part III) exam as satisfying twelve (12) hours of the required twenty-four (24) hours of CME as required by this rule if the national board (Part III) exam was taken within the CME reporting period.

3. A licensee who has obtained American Podiatric Specialty Board certification or recertification during the reporting period shall be deemed to have obtained the required hours of CME. The licensee shall maintain documentation evidencing the certification or recertification.

4. A licensee who participated in a fellowship program in an approved teaching institution shall be deemed to have obtained the required hours of CME if at least sixty (60) days of the reporting period were spent in the fellowship and the fellowship is determined to be advanced training. The licensee shall maintain documentation from the fellowship program director verifying the number of days in the program and that the program is advanced training.

5. Pursuant to section 41.946, RSMo and notwithstanding any other provision of law, any person licensed or certified to practice a trade or profession by the state of Missouri or any branch or agency thereof that requires an annual period of continuing education or training as a condition of continued or renewed licensing or certification, and who is or becomes a member of the National Guard or of any reserve component of the Armed Forces of the United States who is called to full-time active duty in the service of the United States under competent orders shall, during the period of full-time active duty, be exempt

from any such requirement for continuing education or training without his/her status, license, certification or right to practice his/her trade or profession being affected and shall not be required, upon returning from full-time active duty, to make up or retake any training or education for which s/he was exempt under the provisions of this section.

(I) A licensee who cannot complete the required hours of CME because of personal illness or other circumstances beyond the licensee's control, which the board deems to be sufficient to impose an insurmountable hardship may apply for an extension of time to complete the CME requirements. Any extension of time to complete the CME requirements will be granted solely at the discretion of the board. The licensee shall make a written application for extension of time prior to the February 28 deadline for completion of the CME requirement. The application for extension shall be accompanied by the Continuing Medical Education Reporting Period Late Fee. The licensee shall provide full and complete written documentation of the grounds supporting the reasons for which an extension is sought.

1. Illness extensions may be granted only to a licensee who has suffered a personal illness or personal disability of a nature as to prevent him/her from engaging in the active practice of podiatry for at least a majority of the reporting period. At a minimum, the licensee shall provide the board with written documentation from the licensee's treating physician stating the nature of the illness or disability, the period of the illness or disability, any limitations on the licensee's activities that resulted from the illness or disability, documentation of the number of CME hours earned in the two (2)-year reporting period and a plan for completing the balance of the CME requirement.

2. The board, solely at its discretion, may grant an extension based on unforeseeable circumstances beyond the licensee's control that impose an insurmountable hardship precluding the licensee from obtaining the required CME. At a minimum, the licensee shall provide written documentation explaining specifically and in detail the nature of the circumstances, why the circumstances were unforeseeable and beyond the licensee's control, the period during which the circumstances were in existence, documentation of the number of CME credits earned in the two (2)-year reporting period and the licensee's plan for completing the balance of the CME requirement.

3. An extension of time shall not be granted to any licensee who obtained an extension in the immediately preceding CME reporting period in which the licensee held an active license.

(8) Any application for biennial license renewal received by the board more than six (6) months after the renewal date shall be void and the applicant shall be required to make new application and pay the applicable fees in accordance with section 330.030, RSMo, which shall include successful completion of the Missouri Law Examination administered by the board.

(9) A Missouri licensed podiatrist has the ongoing obligation to keep the board informed if the licensee has been finally adjudicated or found guilty, or entered a plea of guilty or *nolo contendere*, in a criminal prosecution under the laws of any state or of the United States, for any offense reasonably related to the qualifications, functions or duties of any profession licensed or regulated under Chapter 330, RSMo, for any offense an essential element of which is fraud, dishonesty, or an act of violence, or for any offense involving moral turpitude, whether or not sentence was imposed. The licensee shall provide this information to the board within thirty (30) days of being finally adjudicated or found guilty.

AUTHORITY: sections 330.010[.2], 330.070, [RSMo 1994, and] and 330.140[.1], RSMo [Supp. 1998] 2000. Original rule filed Dec. 23, 1975, effective Jan. 2, 1976. For intervening history, please

consult the Code of State Regulations. Amended: Filed Sept. 1, 2004.

PUBLIC COST: This proposed amendment will not cost state agencies or political subdivisions more than five hundred dollars (\$500) in the aggregate.

PRIVATE COST: This proposed amendment will not cost private entities more than five hundred dollars (\$500) in the aggregate.

NOTICE TO SUBMIT COMMENTS: Anyone may file a statement in support of or in opposition to this proposed amendment with the Missouri State Board of Podiatric Medicine, PO Box 423, Jefferson City, MO 65102, by facsimile to (573) 751-1155 or by e-mail to podiatry@pr.mo.gov. To be considered, comments must be received within thirty (30) days after publication of this notice in the Missouri Register. No public hearing is scheduled.

**Title 4—DEPARTMENT OF ECONOMIC
DEVELOPMENT
Division 230—State Board of Podiatric Medicine
Chapter 2—General Rules**

PROPOSED AMENDMENT

4 CSR 230-2.041 Public Complaint Handling and Disposition Procedure. The board is proposing to amend sections (1)—(4), and delete the forms immediately following this rule in the *Code of State Regulations*.

PURPOSE: This rule is being amended to delete the forms immediately following this rule in the Code of State Regulations, and to make the text of the rule consistent with terminology currently used by the board.

(1) The State Board of Podiatric Medicine shall receive and process each complaint made against any licensee, permit holder, registrant or applicant of the board, or unlicensed individual or entity, which complaint alleges certain acts or practices which may constitute one (1) or more violations of the provisions of Chapter 330, RSMo. Any member of the public or the profession or any federal, state or local official, may make and file a complaint with the board. Complaints shall be received from sources outside Missouri and processed in the same manner as those originating within Missouri. No member of the State Board of Podiatric Medicine shall file a complaint with this board while holding that office, unless that member is excused from further board deliberations or activity concerning the matters alleged within that complaint. The executive director or any staff member of the board may file a complaint pursuant to this rule in the same manner as any member of the public.

(2) Complaints should be mailed or delivered to the following address: State Board of Podiatric Medicine, 3605 Missouri Boulevard, P[./O./] Box 423, Jefferson City, MO 65102-0423. However, actual receipt of the complaint by the board at its administrative offices in any manner shall be sufficient. Complaints [may] shall be made based upon personal knowledge or upon information and belief, reciting information received from other sources.

(3) All complaints shall be made in writing. [and should, but need not, fully identify the complainant by name and address.] Complaints [may] shall be made on forms provided by the board and available upon request. Oral or telephone communications will not be considered or processed as complaints, but the person making the communications will be provided with a complaint form and requested to complete and return the form to the board in written form. Any member of the administrative staff of the board may make and file a complaint based upon information and belief, in reliance upon oral,

telephone or written communications received by the board, unless that staff member believes those communications to be false.

(4) Each complaint received under this rule shall be logged in a book **and/or database** maintained by the board for that purpose. Complaints shall be logged in consecutive order as received. The log book **and/or database** shall contain a record of each complainant's name and address[, if given]; the name and address of the subject(s) of the complaint; the date each complaint is received by the board; a brief statement of the acts complained of, including the name of any person injured or victimized by the alleged acts or practices; a notation whether the complaint resulted in its dismissal by the board or informal charges being filed with the Administrative Hearing Commission; and the ultimate disposition of the complaint. The log book **and/or database** shall be a closed record of the board.

AUTHORITY: sections 330.140, RSMo [Supp. 1997] 2000 and 620.010.15(6), RSMo Supp. 2003. Original rule filed Feb. 9, 1982, effective May 13, 1982. Amended: Filed Oct. 30, 1997, effective April 30, 1998. Amended: Filed Sept. 1, 2004.

PUBLIC COST: This proposed amendment will not cost state agencies or political subdivisions more than five hundred dollars (\$500) in the aggregate.

PRIVATE COST: This proposed amendment will not cost private entities more than five hundred dollars (\$500) in the aggregate.

NOTICE TO SUBMIT COMMENTS: Anyone may file a statement in support of or in opposition to this proposed amendment with the Missouri State Board of Podiatric Medicine, PO Box 423, Jefferson City, MO 65102, by facsimile to (573) 751-1155 or by e-mail to podiatry@pr.mo.gov. To be considered, comments must be received within thirty (30) days after publication of this notice in the Missouri Register. No public hearing is scheduled.

**Title 4—DEPARTMENT OF ECONOMIC
DEVELOPMENT
Division 230—State Board of Podiatric Medicine
Chapter 2—General Rules**

PROPOSED AMENDMENT

4 CSR 230-2.050 Reciprocity. The board is proposing to amend sections (1), (2) and (3), and add a new section (5).

PURPOSE: This rule is being amended to clarify the requirements for Missouri licensure by reciprocity.

(1) An applicant for a Missouri license by reciprocity [may be granted a license upon satisfying the board that s/he has fulfilled the following requirements:] shall submit an application on the form provided by the board.

(A) [S/he must submit a copy of his/her original license, which was obtained by examination in the state from which s/he is applying for reciprocity. If the applicant was licensed in any state on or after December 4, 1989, the examination requirement of this rule shall be the PMLexis Examination;] The application shall be submitted with the following documentation:

1. A copy of his/her original license, which was obtained by examination in the state from which s/he is applying for reciprocity;
2. Proof of the original licensing state's educational requirements for licensure as a podiatrist, which requirements must be substantially equivalent to the current educational requirements existing in Missouri at the time of application;
3. A recent photograph;

4. The current Reciprocity License Fee; and

5. An official transcript from the college of podiatric medicine from which the applicant graduated. If the applicant attended more than one (1) college of podiatric medicine in order to obtain all of his/her credits for graduation, the applicant shall submit official transcripts from all colleges s/he attended.

(B) [S/he must submit proof of his/her educational qualifications, which must be substantially equivalent to the requirements existing in Missouri at the time s/he originally was licensed;] Application forms may be obtained from the board office at PO Box 423, Jefferson City, MO 65102-0423 or by visiting the board's website at <http://pr.mo.gov/podiatrists.asp>. A copy of the current statutory provisions and board rules regarding the practice of podiatric medicine will be provided with the application form.

(C) [S/he must submit a letter from the secretary of the state board of the state from which s/he is applying attesting—] The applicant shall request that the regulatory entity in each state, United States territory, province, or country in which a license, certificate, registration or permit is held or has ever been held submit verification of licensure, certification, registration or permit directly to the board. The verification shall include the license, registration, certificate or permit issued; the number; status; issue and expiration dates; information regarding any disciplinary action; method of licensure, registration or certification; the name and title of the person verifying information; the date; and the entity's seal.

1. Whether or not s/he is in good standing with the board;

2. Whether there are any complaints pending against him/her; and

3. Whether or not s/he has had his/her license to practice in that state suspended or revoked. The letter shall be transmitted by the writer directly to the board's executive secretary;]

(D) [S/he must submit proof that s/he has been a licensed podiatrist for at least two (2) years next preceding his/her application for a Missouri license by reciprocity; and] No application will be considered unless each section of the application form is fully completed, the form is properly attested and all required documentation is completed and submitted to the board.

(E) [S/he must] A reciprocity applicant shall achieve a score of [seventy-five percent (75%)] **ninety percent (90%)** or greater on the [reciprocity] Missouri Law [e]Examination administered by the board as an open book exam. The applicant shall be required to pay the Missouri Law Examination Administration Fee. The board's [reciprocity] Missouri Law [e]Examination will test the applicant's knowledge of [the] Missouri [podiatry] statutes and rules relating to podiatric medicine. [The examination will be administered at the time an applicant appears before the board as required in section (3) of this rule. Any applicant failing to achieve a score of seventy-five percent (75%) on this examination will be permitted to retake the examination as an open book test. All applicants must achieve at least ninety percent (90%) to be deemed to have passed an open book test over the Missouri podiatry statutes and rules.]

(2) All credentials required by this rule for licensure by reciprocity must be in the possession of the [board's executive secretary] board office at least thirty (30) days before any regular meeting of the board in order for the application to be considered by the board.

(3) [All a]Applicants for licensure by reciprocity [must] may be required to appear in person before the board [before their application will be approved] in order for the application to be approved.

(5) For every person desiring to enter the profession of podiatric medicine within Missouri, the board shall conduct a criminal history background check through the Missouri State Highway Patrol. Applicants shall submit to the board the applicable fee for the criminal history background check as determined by the Missouri State Highway Patrol.

AUTHORITY: sections 330.030 and 330.140[.1], RSMo [1986] 2000. Original rule filed Dec. 23, 1975, effective Jan. 2, 1976. Amended: Filed April 14, 1981, effective July 12, 1981. Rescinded and readopted: Filed Dec. 9, 1981, effective March 11, 1982. Amended: Filed March 4, 1991, effective Sept. 30, 1991. Amended: Filed Feb. 3, 1992, effective June 25, 1992. Amended: Filed Sept. 1, 2004.

PUBLIC COST: This proposed amendment will not cost state agencies or political subdivisions more than five hundred dollars (\$500) in the aggregate.

PRIVATE COST: This proposed amendment will not cost private entities more than five hundred dollars (\$500) in the aggregate.

NOTICE TO SUBMIT COMMENTS: Anyone may file a statement in support of or in opposition to this proposed amendment with the Missouri State Board of Podiatric Medicine, PO Box 423, Jefferson City, MO 65102, by facsimile to (573) 751-1155 or by e-mail to podiatry@pr.mo.gov. To be considered, comments must be received within thirty (30) days after publication of this notice in the Missouri Register. No public hearing is scheduled.

**Title 4—DEPARTMENT OF ECONOMIC
DEVELOPMENT
Division 230—State Board of Podiatric Medicine
Chapter 2—General Rules**

PROPOSED AMENDMENT

4 CSR 230-2.065 Temporary Licenses for Internship/Residency. The board is proposing to amend section (1); add new sections (2), (3) (6), (7), (8) and (9); and renumber and amend previously numbered sections (2), (3) and (4).

PURPOSE: This rule is being amended to clarify the procedures to be used to secure temporary licensure.

(1) *[All applicants for a temporary internship/residency license shall pay the internship/residency registration fee. Temporary internship/residency who apply for a permanent license upon completion of their postgraduate training programs shall be assessed an application processing fee at that time and will be assessed the license fee if approved by the board.] Any applicant desiring to serve a period of internship/residency in a Missouri hospital may do so without obtaining a permanent license from the board if s/he qualifies for and obtains a temporary license for internship/residency for a two (2)-year period from the board. Any applicant desiring to obtain a temporary license shall make application on the form provided by the board. The applicant shall also submit evidence to the board that s/he meets the requirements of this section. There shall be an application fee which shall accompany all applications for a temporary license and shall be nonrefundable.*

(2) Application forms may be obtained from the board office at PO Box 423, Jefferson City, MO 65102-0423 or by visiting the board's website at <http://pr.mo.gov/podiatrists.asp>. A copy of the current statutory provisions and board rules regarding the practice of podiatric medicine will be provided with the application form.

(3) No application will be considered unless it is fully completed and properly attested. Items necessary to complete the application include:

- (A) Each section on the application form itself;
- (B) A recent photograph;
- (C) The current Temporary Application Processing Fee;
- (D) An official transcript from a college of podiatric medicine;
- (E) A certified score report from the National Board of Podiatric Medical Examiners, certifying satisfactory completion of Parts I and II of the National Board Examination;
- (F) A letter from the residency director at the Missouri hospital accredited by the American Podiatric Medical Association where the applicant will be serving his/her internship/residency program with the beginning and ending dates of the postgraduate clinical residency program.

[(2)] (4) No person temporarily [licensed] registered as an [resident/intern may] intern/resident shall practice [podiatry] podiatric medicine outside the physical confines of the sponsoring hospital; provided, however, that an [resident/intern] intern/resident may practice at any facility approved for the residency by the Council on Podiatric Medical Education of the American Podiatric Medical Association.

[(3)] (5) For newly established postgraduate clinical internship/residency programs, a temporary license may be issued to applicants when the postgraduate clinical internship/residency program is accorded preliminary approval or candidate status by the Council on Podiatric Medical Education of the American Podiatric Medical Association. However, [interns/residents] an intern/resident who [apply] applies for a permanent license upon completion of such a[n] postgraduate clinical internship/residency program will not be eligible for permanent licensure until [their] his/her postgraduate clinical internship/residency program completes all the steps necessary for and receives approval or accreditation by the Council on Podiatric Medical Education of the American Podiatric Medical Association. The date on which the Council on Podiatric Medical Education of the American Podiatric Medical Association deems the postgraduate clinical internship/residency program approved or accredited shall be the starting date from which an intern/resident [may] shall receive credit toward the intern's/resident's required period of postgraduate clinical internship/residency.

(6) The temporary license for postgraduate clinical internship/residency, upon approval by the board for good cause shown, may be renewed for an additional one (1)-year period. If during the period of internship/residency specified in the temporary license, the holder thereof shall transfer from the postgraduate clinical internship/residency program offered by the hospital specified in his/her application, the holder must, before such transfer, receive approval for the transfer from the board. Upon approval of the transfer, the temporary license shall remain valid for one (1) year from the original date of issuance.

(7) An applicant approved for a temporary license shall be required to pay the current Temporary License Fee.

(8) For every person desiring to enter the profession of podiatric medicine within Missouri, the board shall conduct a criminal history background check through the Missouri State Highway Patrol. Applicants shall submit to the board the applicable fee for the criminal history background check as determined by the Missouri State Highway Patrol.

(9) Temporary internship/residency applicants who apply for a permanent license upon completion of at least a twelve (12) month postgraduate clinical residency training program shall be assessed the Permanent Application Processing Fee at that time

and shall be assessed the Permanent License Fee if approved by the board.

[(4)] (10) Violation of [section (2) of] this rule [will] shall be treated as cause for initiation of disciplinary proceedings against a temporary license under section 330.160.2(5) and (6), RSMo.

AUTHORITY: sections [330.065, RSMo 1994 and] 330.010, 330.065 and 330.140, RSMo [Supp. 1998] 2000. Original rule filed Dec. 9, 1981, effective March 11, 1982. Amended: Filed Aug. 9, 1993, effective March 10, 1994. Amended: Filed Oct. 25, 1995, effective May 30, 1996. Amended: Filed Oct. 30, 1997, effective April 30, 1998. Amended: Filed June 1, 1999, effective Nov. 30, 1999. Amended: Filed Aug. 12, 1999, effective Feb. 29, 2000. Amended: Filed Sept. 1, 2004.

PUBLIC COST: This proposed amendment will not cost state agencies or political subdivisions more than five hundred dollars (\$500) in the aggregate.

PRIVATE COST: This proposed amendment will not cost private entities more than five hundred dollars (\$500) in the aggregate.

NOTICE TO SUBMIT COMMENTS: Anyone may file a statement in support of or in opposition to this proposed amendment with the Missouri State Board of Podiatric Medicine, PO Box 423, Jefferson City, MO 65102, by facsimile to (573) 751-1155 or by e-mail to podiatry@pr.mo.gov. To be considered, comments must be received within thirty (30) days after publication of this notice in the Missouri Register. No public hearing is scheduled.

| | |
|--|--|
| [(P)] (O) Continuing Education [Sponsor Fee] | |
| Board Review Fee | \$25.00 |
| (P) Background Check Fee | (amount determined by the Missouri State Highway Patrol) |
| (Q) CME Reporting Period Late Fee | \$50.00 |

AUTHORITY: sections 330.095 and 330.140, RSMo 2000. Emergency rule filed June 30, 1981, effective July 9, 1981, expired Nov. 11, 1981. Original rule filed June 30, 1981, effective Nov. 12, 1981. For intervening history, please consult the Code of State Regulations. Amended: Filed Sept. 1, 2004.

PUBLIC COST: This proposed amendment will not cost state agencies or political subdivisions more than five hundred dollars (\$500) in the aggregate.

PRIVATE COST: This proposed amendment is estimated to cost private entities approximately three thousand nine hundred eighty dollars (\$3,980) annually beginning in FY05 and approximately one thousand two hundred fifty dollars (\$1,250) biennially beginning in FY06 for the life of the rule.

NOTICE TO SUBMIT COMMENTS: Anyone may file a statement in support of or in opposition to this proposed amendment with the Missouri State Board of Podiatric Medicine, PO Box 423, Jefferson City, MO 65102, by facsimile to (573) 751-1155 or by e-mail to podiatry@pr.mo.gov. To be considered, comments must be received within thirty (30) days after publication of this notice in the Missouri Register. No public hearing is scheduled.

Title 4—DEPARTMENT OF ECONOMIC DEVELOPMENT
Division 230—State Board of Podiatric Medicine
Chapter 2—General Rules

PROPOSED AMENDMENT

4 CSR 230-2.070 Fees. The board is proposing to amend subsections (1)(C) and (L); delete subsections (1)(A), (K) and (M); add new subsections (1)(B), (D), (P) and (Q); renumber and amend previously numbered subsections (1)(B), (G), (J), (O) and (P); and renumber previously numbered subsections (1)(D), (E), (F), (H), (I) and (N);

PURPOSE: The rule amends various fees charged by the board.

(1) The following fees are established by the State Board of Podiatric Medicine:

| | |
|---|---------------------|
| [(A)] Examination Fee | \$650.00] |
| [(B)] (A) Permanent License Fee | \$100.00 |
| (B) Temporary License Fee | \$50.00 |
| (C) Reciprocity License Fee | [\$750.00] \$350.00 |
| (D) Missouri Law Examination Administration Fee | \$25.00 |
| [(D)] (E) Duplicate License Fee | \$10.00 |
| [(E)] (F) Biennial Renewal Fee | \$350.00 |
| [(F)] (G) Inactive Biennial Renewal Fee | \$200.00 |
| [(G)] (H) Renewal Late Fee (per month) | \$30.00 |
| [(H)] (I) Certification of Grades Fee | \$5.00 |
| [(I)] (J) Reciprocity Certification Fee | \$10.00 |
| [(J)] (K) Certification of Corporation Fee | [\$2.00] \$10.00 |
| [(K)] Print-Out of Licensees Fee | \$5.00] |
| (L) [Internship/Residency Registration] | |
| Temporary Application Processing Fee | \$150.00 |
| [(M)] Reactivation Fee | \$500.00] |
| [(N)] (M) Uncollectible Fee (uncollectible check or other uncollectible financial instrument) | \$25.00 |
| [(O)] (N) Permanent Application Processing Fee | \$250.00 |

PRIVATE ENTITY FISCAL NOTE

I. RULE NUMBER

Title 4 -Department of Economic Development

Division 230 - State Board of Podiatric Medicine

Chapter 2 - General Rules

Proposed Amendment - 4 CSR 230-2.070 Fees

Prepared August 12, 2004 by the Division of Professional Registration

II. SUMMARY OF FISCAL IMPACT

Annual Costs Beginning in FY05

| Estimate the number of entities by class which would likely be affected by the adoption of the proposed amendment: | Classification by type of the business entities which would likely be affected: | Estimated biennial cost of compliance with the amendment by affected entities: |
|--|---|--|
| 11 | Applicants (Temporary License Fee - \$50) | \$550 |
| 8 | Reciprocity Applicants (Type A Fee - \$350) | \$2,800 |
| 18 | Applicants (Examination Administration Fee - \$25) | \$450 |
| 36 | Applicants (Background Check Fee - \$5) | \$180 |
| Estimated Annual Cost of Compliance for the Life of the Rule | | \$3,980 |

Biennial Costs Beginning in FY06

| Estimate the number of entities by class which would likely be affected by the adoption of the proposed amendment: | Classification by type of the business entities which would likely be affected: | Estimated biennial cost of compliance with the amendment by affected entities: |
|--|---|--|
| 25 | Applicants (CME Reporting Period Late Fee - \$50) | \$1,250 |
| Estimated Annual Cost of Compliance for the Life of the Rule | | \$1,250 |

III. WORKSHEET

See table above.

IV. ASSUMPTION

1. The figures reported above are based on FY04 actuals and FY05 projections.
2. The Missouri Highway Patrol establishes the background check fee, therefore, applicants may incur a variance in cost should those fees be increased or decreased.
3. The national examination fee is established by the National Board of Podiatric Medical Examiners, therefore, applicants may incur a variance in cost should those fees be increased or decreased. This fees is paid directly to the National Board of Podiatric Medical Examiners.
4. It is anticipated that the total cost will recur annually for the life of the rule, may vary with inflation and is expected to increase annually at the rate projected by the Legislative Oversight Committee.

**Title 9—DEPARTMENT OF MENTAL HEALTH
Division 45—Division of Mental Retardation and
Developmental Disabilities
Chapter 5—Standards for Community-Based Services**

PROPOSED RESCISSION

9 CSR 45-5.020 Individualized Supported Living Services—Quality Outcome Standards. This rule applied to providers who are certified under the Medicaid waiver program for individualized supported living services. The rule required the provision of services, supports and opportunities necessary for individuals to achieve specified outcomes.

PURPOSE: This rule is being rescinded because it has been superseded by 9 CSR 45-5.010 Certification of Medicaid Agencies Serving Persons with Developmental Disabilities.

AUTHORITY: section 630.050, RSMo 1994. This rule was originally filed as 9 CSR 30-5.020. Emergency rule filed Aug. 4, 1992, effective Sept. 1, 1992, expired Dec. 29, 1992. Original rule filed Aug. 4, 1992, effective Feb. 26, 1993. Amended: Filed May 25, 1995, effective Dec. 30, 1995. Rescinded: Filed Sept. 1, 2004.

PUBLIC COST: This proposed rescission will not cost state agencies or political subdivisions more than five hundred dollars (\$500) in the aggregate.

PRIVATE COST: This proposed rescission will not cost private entities more than five hundred dollars (\$500) in the aggregate.

NOTICE TO SUBMIT COMMENTS: Anyone may file a statement in support of or in opposition to this proposed rescission by writing to Donna Haley, Director, Quality Assurance, Policy and Training, Division of Mental Retardation and Developmental Disabilities, PO Box 687, Jefferson City, MO 65102. To be considered, comments must be received within thirty (30) days after publication of this notice in the Missouri Register. No public hearing is scheduled.

**Title 9—DEPARTMENT OF MENTAL HEALTH
Division 45—Division of Mental Retardation and
Developmental Disabilities
Chapter 5—Standards for Community-Based Services**

PROPOSED RESCISSION

9 CSR 45-5.030 Individualized Supported Living Services—Provider Certification. This rule described procedures to obtain certification from the department as a provider of individualized supported living services reimbursed under the Missouri Medicaid Home and Community-Based Waiver for persons with mental retardation or other developmental disabilities.

PURPOSE: This rule is being rescinded because it has been superseded by 9 CSR 45-5.010 Certification of Medicaid Agencies Serving Persons with Developmental Disabilities.

AUTHORITY: section 630.050, RSMo 1994. This rule was originally filed as 9 CSR 30-5.030. Emergency rule filed Aug. 4, 1992, effective Sept. 1, 1992, expired Dec. 29, 1992. Original rule filed Aug. 4, 1992, effective Feb. 26, 1993. Amended: Filed May 25, 1995, effective Dec. 30, 1995. Rescinded: Filed Sept. 1, 2004.

PUBLIC COST: This proposed rescission will not cost state agencies or political subdivisions more than five hundred dollars (\$500) in the aggregate.

PRIVATE COST: This proposed rescission will not cost private entities more than five hundred dollars (\$500) in the aggregate.

NOTICE TO SUBMIT COMMENTS: Anyone may file a statement in support of or in opposition to this proposed rescission by writing to Donna Haley, Director, Quality Assurance, Policy and Training, Division of Mental Retardation and Developmental Disabilities, PO Box 687, Jefferson City, MO 65102. To be considered, comments must be received within thirty (30) days after publication of this notice in the Missouri Register. No public hearing is scheduled.

**Title 11—DEPARTMENT OF PUBLIC SAFETY
Division 40—Division of Fire Safety
Chapter 3—Fireworks**

PROPOSED RESCISSION

11 CSR 40-3.010 Fireworks—Licenses Sales and Penalties. This rule provided for the administration of 320.106 through 320.161, RSMo.

PURPOSE: This rule is being rescinded due to FY04 statutory changes and the filing of a new proposed rule.

AUTHORITY: section 320.111.9, RSMo Supp. 1988. Original rule filed Sept. 29, 1988, effective Feb. 24, 1989. Amended: Filed May 1, 1989, effective July 13, 1989. Emergency rescission filed Aug. 31, 2004, effective Sept. 10, 2004, expires March 7, 2005. Rescinded: Filed Aug. 31, 2004.

PUBLIC COST: This proposed rescission will not cost state agencies or political subdivisions more than five hundred dollars (\$500) in the aggregate.

PRIVATE COST: This proposed rescission will not cost private entities more than five hundred dollars (\$500) in the aggregate.

NOTICE TO SUBMIT COMMENTS: Anyone may file a statement in support of or in opposition to this proposed rescission with the Missouri Division of Fire Safety, William L. Farr, PO Box 844, Jefferson City, MO 65102. To be considered, comments must be received within thirty (30) days after publication of this notice in the Missouri Register. No public hearing is scheduled.

**Title 11—DEPARTMENT OF PUBLIC SAFETY
Division 40—Division of Fire Safety
Chapter 3—Fireworks**

PROPOSED RULE

11 CSR 40-3.010 Fireworks—Licensing, Permits, Sales, Inspection, and Penalties

PURPOSE: This rule explains the licensing/permit process for the sales, discharge, possession and inspections associated with consumer, display and proximate fireworks.

PUBLISHER'S NOTE: The secretary of state has determined that the publication of the entire text of the material which is incorporated by reference as a portion of this rule would be unduly cumbersome or expensive. This material as incorporated by reference in this rule shall be maintained by the agency at its headquarters and shall be made available to the public for inspection and copying at no more than the actual cost of reproduction. This note applies only to the reference material. The entire text of the rule is printed here.

(1) The following definitions shall be used in interpreting this rule:

(A) *American Pyrotechnics Association (APA), Standard 87-1* (2004), P.O. Box 30438 Bethesda, MD 20824-0348; as incorporated by reference is a standard for manufacturers, importers and distributors of fireworks to assist them in accordance with applicable federal laws;

(B) Chemical composition, all pyrotechnic and explosive composition contained in fireworks devices as defined in *American Pyrotechnics Association (APA), Standard 87-1*;

(C) Consumer fireworks, explosive devices designed primarily to produce visible or audible effects by combustion and includes aerial devices and ground devices, all of which are classified as fireworks, UN0336, 1.4G by regulation of the United States Department of Transportation, Title 49 CFR (2003), 400 7th Street, S.W. Washington, D.C. 20590, as incorporated by reference, and which were formerly classified as class C common fireworks by regulation of the United States Department of Transportation;

(D) Discharge site, the area immediately surrounding the fireworks mortars used for an outdoor fireworks display;

(E) Display site, the immediate area where a fireworks display is conducted, including the discharge site, the fallout area, and the required separation distance from mortars to spectator viewing areas, but not spectator viewing areas or vehicle parking areas;

(F) Display fireworks, explosive devices designed primarily to produce visible or audible effects by combustion, deflagration or detonation. This term includes devices containing more than two (2) grains (130 mg) of explosive composition intended for public display. These devices are classified as fireworks, UN0335, 1.3G by regulation of the United States Department of Transportation, as amended from time-to-time, and which were formerly classified as class B display fireworks by regulation of the United States Department of Transportation;

(G) Distributor, any person engaged in the business of selling fireworks to wholesalers, jobbers, seasonal retailers, other persons, or governmental bodies that possess the necessary permits as specified in sections 320.106 to 320.161, RSMo including any person that imports any fireworks of any kind in any manner into the state of Missouri;

(H) Fireworks, any composition or device for producing a visible, audible, or both visible and audible effect by combustion, deflagration, or detonation and that meets the definition of consumer, proximate, or display fireworks as set forth by 49 CFR part 171 to end, United States Department of Transportation hazardous materials regulations, and *American Pyrotechnics Association, Standard 87-1*;

(I) Fireworks season, the period beginning on the twentieth day of June and continuing through the tenth day of July of the same year and the period beginning on the twentieth day of December and continuing through the second day of January of the next year, which shall be the only periods of time that seasonal retailers may be permitted to sell consumer fireworks;

(J) Illegal fireworks include fireworks whose explosive composition exceeds the limits for consumer fireworks or display fireworks, UN0336, 1.4G, UN0335, 1.3G and UN0431, 1.4G or UN0432, 1.4S by the United States Department of Transportation, and *American Pyrotechnics Association, Standard 87-1* including ground salutes commonly known as cherry bombs, M-80's, M-100's, M-1000's or other fireworks designated with an "M" prefix whose explosive composition exceeds the limits for consumer fireworks by the United States Department of Transportation;

(K) Jobber, any person engaged in the business of making sales of consumer fireworks at wholesale or retail, within the state of Missouri to nonlicensed buyers for use and distribution outside the state of Missouri during a calendar year from the first day of January through the thirty-first day of December;

(L) Licensed operator, any person who supervises, manages, or directs the discharge of outdoor display fireworks, either by manual or electrical means; who has met additional requirements established by promulgated rule and has successfully completed a display fire-

works training course recognized and approved by the state fire marshal;

(M) Manufacturer, any person engaged in the making, manufacture, assembly or construction of fireworks of any kind within the state of Missouri;

(N) NFPA, National Fire Protection Association, Standards 101 (2003 edition), 1123 (2000 edition), 1124 (2003 edition) and 1126 (2001 edition), #1 Batterymarch Park, P.O. Box 9101, Quincy, MA 02269, as incorporated by reference; an international codes and standards organization;

(O) Permanent structure, buildings and structures with permanent foundations other than tents, stands, mobile homes, and trailers;

(P) Permit, the written authority of the state fire marshal issued pursuant to sections 320.106 to 320.161, RSMo, to sell, possess, manufacture, discharge, or distribute fireworks;

(Q) Person, any corporation, association, partnership or individual or group thereof;

(R) Proximate fireworks, a chemical mixture used in the entertainment industry to produce visible or audible effects by combustion, deflagration, or detonation, as defined by the most current edition of the *American Pyrotechnics Association (APA), Standard 87-1*, section 3.8, specific requirements for theatrical pyrotechnics;

(S) Pyrotechnic operator or special effects operator, an individual who has responsibility for pyrotechnic safety and who controls, initiates, or otherwise creates special effects for proximate fireworks and who has met additional requirements established by promulgated rules and has successfully completed a proximate fireworks training course recognized and approved by the state fire marshal;

(T) Sale, an exchange of articles of fireworks for money, including barter, exchange, gift or offer thereof, and each such transaction made by any person, whether as a principal proprietor, salesman, agent, association, copartnership or one or more individuals;

(U) Seasonal retailer, any person within the state of Missouri engaged in the business of making sales of consumer fireworks in Missouri only during a fireworks season as defined by subsection (I) of this section;

(V) Wholesaler, any person engaged in the business of making sales of consumer fireworks to any other person engaged in the business of making sales of consumer fireworks at retail within the state of Missouri.

(2) General Requirements, Licenses, Permits and Fees.

(A) Each firm or person engaged in the manufacture, transportation, wholesale or retail sales of fireworks, public displays utilizing fireworks 1.3G, proximate fireworks 1.4G theatrical, proximate fireworks 1.4S theatrical, pyrotechnic special effects operators, licensed display fireworks operator shall have an applicable license or permit issued by the state fire marshal.

1. License by type:

A. Licensed operator, a fee of one hundred dollars (\$100) for three (3) year license; and

B. Pyrotechnic or special effects operator, a fee of one hundred dollars (\$100) for three (3)-year license.

2. Permits by type:

A. Manufacturer, fee of seven hundred seventy-five dollars (\$775) per calendar year per location;

B. Distributor, fee of seven hundred seventy-five dollars (\$775) per calendar year per location;

C. Wholesaler, fee of two hundred seventy-five dollars (\$275) per calendar year per location;

D. Jobber, a fee of five hundred twenty-five dollars (\$525) per calendar year per location;

E. Seasonal retailer, a fee of fifty dollars (\$50) per calendar year per sales location;

F. Display fireworks, a fee of one hundred dollars (\$100) per calendar year per location;

G. Proximate fireworks display, a fee of one hundred dollars (\$100) per calendar year per location.

(B) All fees shall be paid by cash, money order, or check payable to the Missouri Division of Fire Safety and are nonrefundable or nontransferable except for overpayments resulting from mistakes of law or fact.

(C) All permits except for seasonal retailer shall be for the calendar year or any fraction thereof and shall expire on the thirty-first day of December each year.

(D) Seasonal retail permit shall be valid from the twentieth day of June through the tenth day of July of the same year and the period beginning on the twentieth day of December through the second day of January of the next year.

(E) No seasonal retail, wholesaler or jobber permit shall be issued to a person under the age of eighteen (18) years.

(F) No manufacturer or distributor permit shall be issued to a person under the age of twenty-one (21) years.

(G) No permit or license shall be transferable nor shall a person operate under a permit or license issued to another person or location.

(H) All original permits issued shall be made available for review at the location for which it was issued.

(I) Manufacturer, wholesaler, jobber and distributor permit holders operating out of multiple locations shall obtain a permit for each location.

(J) Upon determining that an applicant has furnished or supplied false information in applying for a license or permit or attempting to renew a license or permit, or has failed to notify the state fire marshal of any change in the information supplied in an application, the state fire marshal may refuse to license or permit the applicant or may revoke or suspend any license or permit issued to the applicant for a period of not more than three (3) years.

(K) The state fire marshal may refuse to issue a license or permit to any applicant when the permit or license of the individual, corporation or partner is under suspension or revocation. The state fire marshal may also refuse to issue a license or permit to a person who is a partner, shareholder, manager, officer, spouse or relative of the applicant or a party to the applicant or is in a position to obtain any financial gain should the application be granted during the period of suspension or revocation.

(L) The state fire marshal may refuse to issue a license or permit for a period not to exceed three (3) years to an applicant whose license or permit has been revoked for the possession or sale of illegal fireworks as referred to in section 320.136, RSMo.

(M) In addition to any other penalty, any person who manufactures, sells, offers for sale, ships or causes to be shipped into or caused to be shipped into Missouri for use in Missouri any items of fireworks without first having obtained the applicable permit or license shall be assessed a civil penalty of up to a one thousand dollars (\$1,000) fine for each day of operation up to a maximum of ten thousand dollars (\$10,000).

(N) Any person aggrieved by any official action of the state fire marshal affecting their license or permit status including revocation, suspension, failure to renew or refusal to issue a license or permit may seek a determination by the Administrative Hearing Commission pursuant to the provisions of section 621.045, RSMo.

(3) Applications for Permit—Manufacturer, Distributor, Wholesaler, Jobber, Seasonal Retail.

(A) Applications for a permit shall be on forms provided by the state fire marshal and shall be accompanied by the appropriate fee and documentation as required.

1. Copy of Missouri retail sales tax license.

2. Copy of current certificate of "No Tax Due" for the preceding year obtained from Missouri Department of Revenue, except if the applicant is pursuing any proper remedy at law challenging the amount, collection, or assessment of any sales tax.

3. If applicable, copy of "Certificate of Good Standing" from Missouri Secretary of State.

4. Copy of applicable federal license or permit.

(B) Failure to make application for seasonal retail permit by May thirty-first of the calendar year may result in the fire marshal's refusal to issue a permit to the applicant for such calendar year.

(C) Every application for a permit to sell fireworks shall be signed by the permittee or a responsible agent for the permittee who, by signing the application, acknowledges that the permittee will take reasonable steps to see that all employees, agents and officers of the permittee will be familiar with all rules applicable to fireworks operations and will abide by those rules.

(4) Requirements: Manufacturer, Distributor, Jobber or Wholesaler.

(A) A holder of a manufacturer's permit shall not be required to have any additional permits in order to sell to distributors, wholesalers, jobbers or seasonal retailers, or to sell display or proximate fireworks.

(B) A holder of a distributor's permit shall not be required to have any additional permit in order to sell to wholesalers, jobbers, seasonal retailers or to sell display or proximate fireworks.

(C) A holder of a jobber's permit shall not be required to have any additional permit in order to sell consumer fireworks at retail during the fireworks season from such jobber's permanent structure.

(D) Any wholesale transaction by a manufacturer, distributor, wholesaler or jobber to any seasonal retailer doing business in Missouri shall be permitted only if the purchaser has been issued a seasonal retail permit from the state fire marshal as a seasonal retailer.

(E) Any sales by jobbers and wholesalers during any period of time other than the fireworks season as defined in section 320.106(3), RSMo, shall be to nonresidents of Missouri, or to residents of Missouri only after a reasonable inquiry and a waiver signed by the buyer on a form provided by the state fire marshal indicating that the fireworks are for use outside of Missouri if the sale is a retail transaction.

(F) A holder of a manufacturer, distributor, wholesaler or jobber's permit shall be required to operate out of a permanent structure in compliance with applicable building and fire regulations in the city or county where located.

(G) Any person engaged in more than one (1) permit classification shall pay one (1) permit fee based upon the permit classification yielding the highest amount of revenue.

(H) Any person, entity, partnership, corporation, or association transporting display or proximate fireworks into Missouri for the purpose of resale, or to conduct a 1.3G fireworks display, or to conduct a proximate fireworks display shall be permitted by the state fire marshal as a distributor or manufacturer and have obtained applicable federal license or permit.

(I) Sale of display or proximate fireworks shall be limited to a holder of a federal license or permit and a distributor or manufacturer permit issued by the state fire marshal.

(J) No holder of a manufacturer or distributor permit shall sell, barter, or transfer display or proximate fireworks to anyone not possessing an applicable permit or license.

(K) No wholesaler or jobber, or any other person shall sell, offer for sale, store, display, or have in their possession any consumer fireworks that have not been approved as fireworks UN0336, or 1.4G by the United States Department of Transportation.

(L) Possession of display or proximate fireworks for resale to holders of a permit for display or proximate fireworks shall be confined to a holder of a manufacturer or distributor permit and applicable federal license or permit.

(M) No jobber, wholesaler, manufacturer, or distributor shall sell to seasonal retail dealers, or any other person in this state for the purpose of resale, or use in this state, any consumer fireworks which do not have the numbers and letter "1.4G" printed with an orange diamond shaped label printed on or attached to the fireworks shipping carton.

(N) Possession of display or proximate fireworks shall be limited to:

1. A holder of a display or proximate fireworks permit issued by the authority having jurisdiction where the display or proximate fireworks display is proposed to be held; or

2. A holder of a display or proximate fireworks permit issued by the state fire marshal; or

3. A holder of a state manufacturer or distributor permit and applicable federal license or permit.

(5) Requirements: Seasonal Retail Sales.

(A) A seasonal retail permit shall be required for each retail sales location.

(B) Consumer fireworks 1.4G shall be sold to the general public only from permitted seasonal retail sites and only during the fireworks season as defined in section (1) of this rule.

(C) It is unlawful to attempt to sell or to sell any fireworks to children under the age of fourteen (14) years except when such child is in the presence of a parent or guardian.

(D) It is unlawful for any person under the age of sixteen (16) to sell fireworks or work in a facility where fireworks are stored, sold, or offered for sale unless under the supervision of an individual at least eighteen (18) years of age.

(E) Seasonal retail permit locations shall be in compliance with all applicable building and fire regulations and may be subject to a fire safety inspection by the state fire marshal per section (7) of this rule.

(F) A seasonal retailer shall acquire and present the appropriate permit from the state fire marshal before any manufacturer, distributor, wholesaler or jobber is allowed to sell consumer fireworks to such seasonal retailer provided that such retailer is purchasing the consumer fireworks for resale in this state.

(6) General Requirements; Fireworks Safety/Authority to Inspect.

(A) Fireworks shall not be stored, kept, or sold within fifty feet (50') of any gasoline pump, gasoline filling station, gasoline bulk station, or any building in which gasoline or volatile liquids are sold in quantities in excess of one (1) gallon.

(B) Fireworks shall not be manufactured, stored, kept or sold within one hundred feet (100') of any dispensing unit for ignitable liquids or gases.

(C) It is unlawful to explode or ignite consumer fireworks within six hundred feet (600') of any church, hospital, mental health facility, or school or within one hundred feet (100') of any location where fireworks are stored, sold or offered for sale.

(D) No person shall ignite or discharge fireworks within three hundred feet (300') of any permanent storage of ignitable liquid, gases, gasoline pump, and gasoline filling station.

(E) No person shall ignite or discharge any fireworks within or throw the same from or into a motorized vehicle including watercraft or any other means of transportation or at or near any person or group of people, except where display permit has been issued for a floating vessel or floating platform.

(F) All person(s) selling or offering fireworks for sale or barter or trade will permit the state fire marshal and the marshal's deputies to conduct inspections, based on *Code of State Regulations*, of the business premises or any location where fireworks are stored or kept and will cooperate with any inspection or investigation. Failure to cooperate or refusal to allow an inspection shall result in suspension or revocation of the permittee's permit(s) or refusal of a permit to be issued. This inspection shall be performed during normal business hours.

(7) Requirements; Fire Safety Inspection—Retail Sales.

(A) Portable Fire Extinguishers.

1. Every seasonal retail sales location shall have not less than two (2) portable fire extinguishers with a minimum 2A rating, at least one (1) of which shall be a pressurized water type.

2. Temporary seasonal retail sales locations less than two hundred (200) square feet in area shall be required to have at least one (1) portable fire extinguisher with a minimum 2A rating.

3. The maximum travel distance to a fire extinguisher in any seasonal retail sales location shall be no greater than thirty-five feet (35').

4. All fire extinguishers shall be inspected annually by a fire extinguisher company and have documentation to this effect attached to them.

5. All fire extinguishers shall be located in an accessible location to the staff.

6. Employees shall be trained to operate fire-extinguishing equipment and shall be required to exhibit their skill when requested by the authority having jurisdiction.

(B) Site Requirements.

1. The authority having jurisdiction shall require a certificate or other evidence of acceptance by an organization or laboratory of recognized standing or manufacturer verifying that the tent fabric material has been treated with a flame resistant material.

2. No hay, straw, shavings, or similar combustible materials that have not been treated to make them flame retardant shall be permitted within any seasonal retail sales location.

3. The area located within thirty feet (30') of a retail sales location shall be kept free of accumulated dry grass, dry brush, and combustible debris.

4. Fireworks shall not be displayed or stored behind glass through which direct sunlight will shine on the fireworks except for where the fireworks are in their original package.

5. Fireworks shall be kept in a location out of the reach of the public when an attendant is not on duty.

6. Seasonal retail sales locations shall be secured when unoccupied and not open for business.

(C) Fireworks Discharge.

1. Fireworks shall not be ignited, discharged, or otherwise used within one hundred feet (100') of any location where fireworks are stored, sold, or offered for sale.

2. At least one (1) sign that reads as follows, in letters at least four inches (4") high on a contrasting background, shall be conspicuously posted at each entrance of seasonal retail sales locations:

NO FIREWORKS DISCHARGE WITHIN 100 FEET

(D) No Smoking Signs.

1. Smoking shall not be permitted inside or within twenty-five feet (25') of the seasonal retail sales area.

2. One (1) or more signs reading, "FIREWORKS—NO SMOKING" shall be displayed at each entrance of seasonal retail sales locations in letters not less than four inches (4") in height on a contrasting background.

(E) Separation Distances.

1. No motor vehicle shall be parked within ten feet (10') of a seasonal retail sales location.

2. No trailer used for the storage of consumer fireworks shall be parked within ten feet (10') of a seasonal retail sales location.

3. Temporary seasonal retail sales stands and tent side walls shall not be located within twenty feet (20') of the following, unless authorized by the authority having jurisdiction:

- A. Another building;
- B. Another seasonal retail sales location;
- C. Cooking equipment of any type.

4. Seasonal retail sales locations shall not be located within fifty feet (50') of the following:

- A. Any gasoline pump, gasoline filling station, gasoline bulk station, or any building in which gasoline or volatile liquids are sold in quantities in excess of one (1) gallon;
- B. Compressed natural gas dispensing facilities;
- C. Retail propane dispensing station;
- D. Aboveground storage tanks for flammable or combustible liquid, flammable gas or flammable liquefied gas;
- E. Any type of open flame cooking equipment.

5. Portable generators shall be located not less than twenty feet (20') from a seasonal retail sales location.

(F) Means of Egress.

1. All means of egress from any temporary seasonal retail sales tent or stand shall remain clear and free of obstructions.

2. A minimum of two (2) remote means of egress shall be located in a seasonal retail sales location.

3. Exits provided for temporary seasonal retail sales stands shall be arranged so that the maximum egress travel distance does not exceed thirty-five feet (35').

4. Exits provided for seasonal retail tents shall be arranged so that the maximum egress travel distance measured from the most remote point to an exit along the natural and unobstructed path of egress travel, does not exceed seventy-five feet (75').

5. Aisles within a temporary seasonal retail sales tent, where the interior is accessible to the public, the minimum clear width shall be permitted to be not less than forty-eight inches (48").

6. Aisles within a temporary seasonal retail sales stand, where the interior is not accessible to the public, the minimum clear width shall be permitted to be not less than twenty-eight inches (28").

7. The required width of aisles shall be maintained unobstructed at all times the facility is occupied by the public.

8. Dead end aisles shall be prohibited.

9. Exit openings from seasonal retail sales tents shall be not less than forty-four inches (44") in width.

10. Egress doors in temporary seasonal retail sales stands where the interior is not accessible to the public shall be permitted to be not less than twenty-eight inches (28") in width.

11. Egress doors in temporary seasonal retail sales stands where the interior is accessible to the public shall be permitted to be not less than thirty-six inches (36") in width.

12. No fireworks shall be displayed for sale or stored within two feet (2') of any public exit, or private entrance or exit in an enclosed building.

(G) Exit Signs and Emergency Lighting.

1. Exit signs shall be required to be self-luminous or internally or externally illuminated.

2. Exit signs shall not be required to be illuminated in tents or stands that are not open for business after dusk or in temporary seasonal retail sales stands where the interior is not accessible to the public.

3. Emergency lighting shall not be required in tents or stands that are not open for business after dusk or for temporary seasonal retail sales stands where the interior is not accessible to the public.

4. Emergency lighting shall be required as deemed necessary by the fire inspector or authority having jurisdiction.

(H) Electrical Equipment.

1. The electrical system and equipment shall be isolated from the public by proper elevation or guarding, and all electrical fuses and switches shall be enclosed in approved enclosures.

2. Electrical cables, including extension cords on the ground in areas traversed by the public shall be placed in trenches or protected by approved covers.

3. All extension cords shall be a minimum fourteen (14) gauge and multi-outlet power strips shall be UL approved and of the grounding type.

4. All multi-outlet power strips shall be UL approved and of the type with a circuit breaker for overload protection.

5. All electrical wiring, equipment, and devices shall be UL approved, installed and maintained to prevent electrical hazards.

6. All electrical lighting shall be UL approved, mounted and installed in a safe manner.

7. Branch circuits for receptacles, lighting and other uses shall be protected by ground fault circuit interrupters if susceptible to water exposure.

8. The power distribution panel shall be properly grounded with a minimum #6 solid copper wire connected to a copper clad ground

rod. The ground wire must be connected to the ground rod using a UL approved ground rod clamp with the clamp being visible.

(I) Prohibited activity/items.

1. The retail sales of pest control devices, including their related storage and display shall be prohibited.

2. No electronic pest control device(s) shall be located inside a seasonal retail sales location.

3. The consumption or possession of alcoholic beverages in any seasonal retail sales location is prohibited during business hours.

4. Any person selling fireworks shall not knowingly sell consumer fireworks to any person who is obviously under the influence of alcohol or drugs.

5. Proximate fireworks shall not be allowed to be sold with consumer fireworks.

(8) Permit Requirements; Discharging Display or Proximate Fireworks.

(A) Permit(s) for display or proximate fireworks may be granted to municipalities, fair associations, amusement parks, organizations, persons, firms or corporations. Such permits may be granted upon application and approval by the state fire marshal or local authority having jurisdiction where the display is proposed to be held.

1. Application for a permit to conduct a display/proximate fireworks show issued by the state fire marshal shall meet the following requirements and be on a form provided by the state fire marshal:

A. Applicant shall be at least twenty-one (21) years of age;

B. The permit shall be issued per location per calendar year, except—

(I) Any change from the original site plan relating to distances, mortar size, mortar installation, firing method, etc. shall require a new application and submission of an additional permit fee;

C. A fee of one hundred dollars (\$100) shall be paid to the state fire marshal at the time of initial application for permit;

D. Identity of state licensed display/pyrotechnic operator shall be provided;

E. Applicant shall submit proof of insurance coverage insuring the applicant with liability insurance in order to satisfy claims for damages to property or personal injuries arising out of any act or omission on the part of such person, firm or corporation or any agent or employee thereof with an occurrence limit of not less than one (1) million dollars. Additionally, insurance coverage of an employer for whom the individual is employed shall be considered to comply with the aforementioned, if the coverage provides equivalent coverage for each employee;

F. If applicant is conducting a display under the auspices of a municipality or political subdivision the applicant shall be exempt from liability insurance coverage if the municipality or political subdivision possesses liability insurance covering the applicant with an occurrence limit of not less than one (1) million dollars;

G. Applicant shall submit a detailed site plan, to include but not be limited to distance requirements per NFPA, firing method, mortar installation and product being used along with the name of the licensed or pyrotechnic operator to the state fire marshal a minimum of ten (10) working days prior to the date of the event;

H. Upon request applicant shall provide Material Safety Data Sheets (MSDS) relating to the products being used;

I. No permit granted shall be transferable;

J. The permit shall apply to only one (1) location.

2. A copy of a display or proximate fireworks permit issued by the local authority having jurisdiction shall be submitted by the permit holder to the state fire marshal within forty-five (45) days of the display or upon request of the state fire marshal.

3. Any venue where proximate fireworks are to be discharged shall be inspected by the state fire marshal or local authority having jurisdiction for compliance with NFPA 1126.

4. Any establishment where proximate fireworks are to be discharged indoors shall be inspected by the state fire marshal or local authority having jurisdiction for compliance with NFPA 1126 and

NFPA 101 *Life Safety Code* or equivalent nationally recognized code in relation to means of egress, occupancy load, and automatic sprinkler and fire alarm systems.

5. Provisions shall be made for adequate fire protection at a level determined by the jurisdiction where the display is to be conducted.

6. Safety monitors shall be required per NFPA 1123 and/or NFPA 1126.

7. This subsection shall not preclude a political subdivision, county or city from imposing by ordinance the requirement to notify local authorities of the intent to conduct such display.

(9) Licensed/Pyrotechnic Display Operator.

(A) Every fireworks display or proximate fireworks display shall be supervised, managed, or directed by a Missouri state licensed operator or pyrotechnic operator on-site.

(B) Licensed/pyrotechnic display operators shall complete and submit, on a form provided by the state fire marshal a licensed/pyrotechnic display operator application and meet the minimum requirements listed below:

1. Applicant shall be at least twenty-one (21) years of age;
2. Applicant shall not have a felony conviction or have pleaded guilty to a felony;
3. A fee of one hundred dollars (\$100) shall be paid to the state fire marshal at the time of application for licensure;
4. Applicant shall provide two (2) passport type photographs per license requested;
5. The state fire marshal will consider the following criteria in determining whether to issue a license to the applicant under the provisions of this rule:

A. Documentation that applicant has attended courses relating to pyrotechnics;

B. An applicant shall submit evidence of experience, which must include active participation as an assistant or operator in the performance of at least three (3) fireworks displays or proximate fireworks displays, at least one of which must have occurred in the current or preceding year;

C. Applicant shall complete a written examination administered by the state fire marshal and achieve a passing score of at least seventy percent (70%).

(I) Any person failing to pass the examination may retake the examination after a thirty (30)-day waiting period.

(II) Any person failing to pass the examination a second time may retake the examination after a ninety (90)-day waiting period;

D. Any licenses or certifications from other jurisdictions or licensing entities approved by the state fire marshal;

E. References from local authorities, sponsors, employers, and fireworks/pyrotechnic companies;

F. Copy of U.S. Bureau of Alcohol, Tobacco, Firearms and Explosives permit/license if applicable;

6. To obtain recertification, the applicant shall be required to meet the following criteria:

A. Provide documentation that applicant has attended a minimum of twelve (12) hours of continuing education relating to pyrotechnics within the past three (3) years.

B. Provide documentation of actively participating in at least three (3) fireworks displays or proximate fireworks displays.

C. A fee of one hundred dollars (\$100) shall be paid at the time of recertification to the state fire marshal;

7. The licensee shall carry his/her license at all times when engaging in pyrotechnic display activity;

8. Each license issued pursuant to this section shall specify the licensee's name, state issued license number, the license's effective date and expiration date and photograph;

9. In any case where the state fire marshal denies, suspends or revokes a license, a written notice of the basis for the denial, sus-

pension or revocation shall be provided to the applicant or license holder;

10. Upon notice of revocation or suspension, the license holder shall surrender the license and all copies thereof to the state fire marshal immediately. No person shall supervise a fireworks display or proximate display once their license has been revoked or suspended;

11. Upon notice of denial, suspension or revocation of a license, the decision may be appealed in writing to the state fire marshal within forty-five (45) days of the denial, suspension or revocation requesting an administrative hearing pursuant to the provisions of section 621.045, RSMo;

12. The state fire marshal may deny, suspend or revoke licensure of any applicant when it is found that the applicant or licensee:

A. Has knowingly made a material misrepresentation of any information required for licensure;

B. Has knowingly by any means of false pretense, deception, fraud, misrepresentation or cheating obtained training or licensure;

13. No person shall handle display/proximate fireworks or cause any person to handle or discharge display/proximate fireworks in this state unless such use of display/proximate fireworks are under the direct supervision and responsibility of a state licensed operator or pyrotechnic operator pursuant to this rule. Persons working under the direct supervision of a licensed operator or pyrotechnic operator at the site shall not be in violation of this rule.

(10) Violations.

(A) A permittee will receive a written warning from the state fire marshal for violation of any of the following:

1. Failing to properly display a No Smoking sign(s);
2. Failing to properly display a No Smoking sign(s) of sufficient size;
3. Failing to properly display a permit or license;
4. Selling or offering for sale fireworks that are not properly labeled;
5. Exposing fireworks to direct sunlight while displayed and unattended, as defined by section 320.146.1, RSMo;
6. Leaving unattended fireworks accessible to the public;
7. Attempting to make or making a sale of fireworks out of season as defined in section 320.106(9), RSMo to someone for use or distribution within the state of Missouri;
8. Knowingly allowing an open flame or smoking within twenty-five feet (25') of a place where fireworks are manufactured, stored, kept, or offered for sale;
9. Selling to a child under the age of fourteen (14) who is not in the presence of his/her parent or guardian;
10. Receiving fireworks without a permit if the permittee was permitted but failed to renew;
11. Selling fireworks without a permit if the permittee was permitted but failed to renew;
12. Selling from other than a permanent structure, except for retail sales during fireworks seasons;
13. Storing fireworks too close to volatile liquids or gases, as defined by section 320.146(2), RSMo;
14. Selling or shipping fireworks to a consumer within a city or county lawfully prohibiting the sale or possession of fireworks pursuant to section 320.121, RSMo;
15. Employing a person less than sixteen (16) years of age who is unsupervised;
16. Selling or offering for sale or displaying fireworks to consumers that are marked other than UN0336, 1.4G;
17. Failure of distributors and manufacturers to retain copies of applicable permit(s) or license(s) issued for display and/or proximate fireworks transactions for one (1) year after the transaction.

(B) Subsequent violation of any of the acts set forth in subsection (10)(A) will result in the suspension or revocation of the permit(s) of the permittee for a period as determined by the state fire marshal.

(C) Violation of any of the following laws or regulations may result in the suspension or revocation of the permit(s) for a period not to

exceed three (3) years and/or the refusal of the fire marshal to renew or issue a permit(s) to the permittee or owner:

1. Selling or improperly possessing fireworks while the permit or license has been suspended or revoked;
2. Allowing another person or business to use or display the license of a licensee;
3. Possessing or manufacturing illegal fireworks or selling or offering for sale illegal fireworks as defined in section 320.136, RSMo;
4. Failing or refusing to allow a reasonable inspection of any premises and all portions of buildings where fireworks are being stored or are being offered for sale. A reasonable request is one made either during daylight hours or while the premises or building are open for business;
5. Failing to fully cooperate with a reasonable request during an inspection;
6. Failure to obtain a permit for display or proximate fireworks site;
7. Performing a display or proximate fireworks display without having obtained a licensed operator or pyrotechnic operator permit from the Missouri State Fire Marshal;
8. Selling fireworks for resale in this state to a distributor, manufacturer, jobber, wholesaler or seasonal retailer who has not first obtained their current permits as required by law;
9. Failure of the applicant to obtain all required permit(s) and/or license(s) required as per 320.111(1), RSMo.

(D) The state fire marshal will indicate to the permit holder, in writing, the statute(s) and any regulations violated. Appeals from any decision of the state fire marshal will be made to the Administrative Hearing Commission, except in cases in which a charged violation includes a violation of the criminal laws.

(E) The period of suspension or revocation imposed by the state fire marshal will remain in effect against the permit holder's future business, partnership, corporation or entity even if an attempt to change ownership or control of that permit holder's business, partnership, corporation or entity is made or attempted.

(F) Persons found guilty of handling or discharging display/proximate fireworks, or directing, ordering or otherwise causing any person to handle or fire display/proximate fireworks in this state without having a valid license shall be guilty of a Class A misdemeanor.

(11) Incident Reporting; Licensed Operator/Pyrotechnic Operator Responsibility.

(A) It is the responsibility of the licensed operator/pyrotechnic operator to immediately report any discharge related incident identified below to local law enforcement or fire service agencies and request such agency to notify the Office of the State Fire Marshal—

1. Injury to any person requiring immediate medical treatment;
2. A fire or damage to property in an amount reportable to the operator's insurance company;
3. Loss of life.

(B) After a reportable incident has occurred, the scene shall not be altered or tampered with in any manner unless authorized by the state fire marshal or designee, until an investigation/inspection can be completed.

(C) Failure of the licensed operator/pyrotechnic operator to report an incident identified in this section may be subject to their license being suspended or revoked by the state fire marshal for a period of time not to exceed (3) years.

PUBLIC COST: This proposed rule will cost state agencies or political subdivisions sixteen thousand six hundred fifty dollars (\$16,650) in the aggregate.

PRIVATE COST: This proposed rule will cost private entities sixty-three thousand nine hundred fifty dollars (\$63,950) in the aggregate.

NOTICE TO SUBMIT COMMENTS: Anyone may file a statement in support of or in opposition to this proposed rule with the Missouri Division of Fire Safety, William L. Farr, Director, PO Box 844, Jefferson City, MO 65102. To be considered, comments must be received within thirty (30) days after publication of this notice in the Missouri Register. No public hearing is scheduled.

AUTHORITY: section 320.III.9, RSMo Supp. 2004. Original rule filed Sept. 29, 1988, effective Feb. 24, 1989. Amended: Filed May 1, 1989, effective July 13, 1989. Emergency rescission and rule filed Aug. 31, 2004, effective Sept. 10, 2004. expires March 9, 2005. Rescinded and readopted: Filed Aug. 31, 2004.

**FISCAL NOTE
PUBLIC COST**

I. RULE NUMBER

| | |
|-----------------------|--|
| Rule Number and Name: | 11CSR40-3.010 Fireworks—Licensing, Permits, Sales, Inspection, and Penalties |
| Type of Rulemaking: | Proposed Rule |

II. SUMMARY OF FISCAL IMPACT

| Affected Agency or Political Subdivision | Estimated Cost of Compliance in the Aggregate |
|--|---|
| Mo. Division of Fire Safety | \$16,650 |
| | |
| | |

III. WORKSHEET

Estimate costs related to postage, copying, office supplies, etc. to be approximately \$4,500.

Cost to administer licensing and application process by Division staff is estimated to be approximately \$7,150

Approximately 520 hours devoted to administer program, staff hourly salary \$13.75.

520 hours X \$13.75 = \$7,150

An estimated (50) site plan reviews will be conducted with the average cost per review to be \$100. This will involve various Division staff to conduct the plan review then field staff will be required to conduct an onsite review. Expenses associated include, salary, travel expenses.

IV. ASSUMPTIONS

The Division of Fire Safety will review applications from individuals desiring to be state licensed to conduct public fireworks displays or proximate fireworks displays and issue such license. In addition, this rule requires a plan review of the site where display or proximate fireworks are discharged for public viewing unless permitted by the local authority having jurisdiction.

**FISCAL NOTE
PRIVATE COST**

I. RULE NUMBER

| | |
|-----------------------|--|
| Rule Number and Name: | 11CSR40-3.010 Fireworks-Licensing,Permits,Sales,Inspection and Penalties |
| Type of Rulemaking: | Proposed Rule |

II. SUMMARY OF FISCAL IMPACT

| Estimate of the number of entities by class which would likely be affected by the adoption of the proposed rule: | Classification by types of the business entities which would likely be affected: | Estimate in the aggregate as to the cost of compliance with the rule by the affected entities: |
|--|--|--|
| Fireworks Industry | See Below | \$63,950 |
| | | |
| | | |

II. WORKSHEET

All permit fees were increased and estimates are based upon FY04 permits issued.

Estimates based upon FY04 permits issued:

Manufacturers (6) x \$25 = \$150

Distributors (40) x \$25 = \$1,000

Wholesaler(s) (13) x \$25 = \$325

Jobber(s) 66 x \$25 = \$1,650

Seasonal retailer(s) 1373 x \$25 = \$34,325

Display/proximate fireworks display permits (40) x \$100 = \$4,000

Display/proximate operator license(s) (225) x \$100 = \$22,500 (3 year license)

IV. ASSUMPTIONS

The Division of Fire Safety will issue permits to manufacturers, distributors,wholesalers,jobbers and seasonal retailers that sell fireworks. In addition, individuals desiring to conduct display/proximate fireworks shows must obtain a state license based upon completion of specific levels of training and testing. Display/proximate fireworks shows also require a state or local permit to be issued before conducting the show to include a site inspection.

**Title 11—DEPARTMENT OF PUBLIC SAFETY
Division 45—Missouri Gaming Commission
Chapter 1—Organization and Administration**

PROPOSED RULE

11 CSR 45-1.100 Waivers and Variances

PURPOSE: This rule permits licensees to apply for and receive waivers or variances to regulatory requirements.

(1) The commission may waive or grant a variance from the provisions of Title 11, Division 45, Chapters 1–31 of the *Code of State Regulations* upon a licensee's written application, if the commission determines that the waiver or variance is in the best interests of the public. Any waiver or variance granted pursuant to this section constitutes an order of the commission pertaining to gaming, violation of which subjects a licensee to discipline under section 313.812.14(2), RSMo.

(2) In granting any variance authorized by this section, the commission may impose certain conditions and restrictions with which the licensee must comply to accept and use the variance. Failure to meet the conditions or restrictions contained in the variance will immediately render the variance void, and the licensee may be subject to discipline in the same manner as if the variance had never been issued.

AUTHORITY: sections 313.004 and 313.805, RSMo 2000. Original rule filed Aug. 27, 2004.

PUBLIC COST: This proposed rule will not cost state agencies or political subdivisions more than five hundred dollars (\$500) in the aggregate.

PRIVATE COST: This proposed rule will not cost private entities more than five hundred dollars (\$500) in the aggregate.

NOTICE OF PUBLIC HEARING AND NOTICE TO SUBMIT COMMENTS: Anyone may file a statement in support of or in opposition to this proposed rule with the Missouri Gaming Commission, PO Box 1847, Jefferson City, MO 65102. To be considered, comments must be received within thirty (30) days after publication of this notice in the *Missouri Register*. A public hearing is scheduled for November 17, 2004 at 10 a.m., in the Missouri Gaming Commission's Hearing Room, 3417 Knipp Drive, Jefferson City, Missouri.

**Title 11—DEPARTMENT OF PUBLIC SAFETY
Division 45—Missouri Gaming Commission
Chapter 4—Licenses**

PROPOSED AMENDMENT

11 CSR 45-4.260 Occupational Licenses. The commission is amending subsection (4)(N).

PURPOSE: The commission proposes to amend this rule by eliminating the "For any just cause" grounds for denial or discipline of an occupation license and replace it with a prohibition against making false or misleading statements to the commission or its agents.

(4) The commission may refuse an occupational license to any person or revoke an occupational license of any person—

(N) [For any just cause] Who provides the commission or its agents with false or misleading information, documents, or data or who makes false or misleading statements to the commission or its agents;

AUTHORITY: sections 313.004 and 313.805, RSMo 2000. Emergency rule filed Sept. 1, 1993, effective Sept. 20, 1993, expired Jan. 17, 1994. Emergency rule filed Jan. 5, 1994, effective Jan 18, 1994, expired on Jan. 30, 1994. Original rule filed Sept. 1, 1993, effective Jan. 31, 1994. For intervening history, please consult the *Code of State Regulations*. Amended: Filed April 28, 2004.

PUBLIC COST: This proposed amendment will not cost state agencies or political subdivisions more than five hundred dollars (\$500) in the aggregate.

PRIVATE COST: This proposed amendment will not cost private entities more than five hundred dollars (\$500) in the aggregate.

NOTICE OF PUBLIC HEARING AND NOTICE TO SUBMIT COMMENTS: Anyone may file a statement in support of or in opposition to this proposed amendment with the Missouri Gaming Commission, PO Box 1847, Jefferson City, MO 65102. To be considered, comments must be received within thirty (30) days after publication of this notice in the *Missouri Register*. A public hearing is scheduled for 10 a.m. on November 17, 10:00 a.m., in the Missouri Gaming Commission's Hearing Room, 3417 Knipp Drive, Jefferson City, Missouri.

**Title 11—DEPARTMENT OF PUBLIC SAFETY
Division 45—Missouri Gaming Commission
Chapter 12—Liquor Control**

PROPOSED AMENDMENT

11 CSR 45-12.090 Rules of Liquor Control. The commission is amending subsection (5)(A).

PURPOSE: The commission proposes to amend this rule by removing prohibitions on casino employees receiving nonalcoholic drinks from patrons or sitting or dancing with patrons. Prohibitions on tips and gifts are also deleted, but are governed by regulations in other chapters.

(5) Employees.

(A) Except upon written authorization from the director as provided in subsection (5)(B), no holder of an excursion liquor license shall give to, sell or permit to be given to or sold to any gaming employee of the establishment operated by the licensee, any intoxicating liquor, in any quantity, nor shall [s/he/it] the holder of an excursion liquor license permit any patron of the establishment operated by [him/her/it] the licensee to give to any gaming employee any intoxicating liquor, in any quantity, [nonalcoholic beverage, drink, merchandise or other thing of value in any quantity,] or to purchase it for[,] or drink it with[, sit at the bar or tables with or dance with] any gaming employee in the establishment or on the premises of the licensee.

AUTHORITY: sections 313.004 and 313.805, RSMo 2000 and 313.840, RSMo Supp. [2001] 2003. Emergency rule filed Sept. 1, 1993, effective Sept. 20, 1993, expired Jan. 17, 1994. Emergency rule filed Jan. 5, 1994, effective Jan. 18, 1994, expired Jan. 30, 1994. Original rule filed Sept. 1, 1993, effective Jan. 31, 1994. For intervening history, please consult the *Code of State Regulations*. Amended: Filed Aug. 27, 2004.

PUBLIC COST: This proposed amendment will not cost state agencies or political subdivisions more than five hundred dollars (\$500) in the aggregate.

PRIVATE COST: This proposed amendment will not cost private entities more than five hundred dollars (\$500) in the aggregate.

*NOTICE OF PUBLIC HEARING AND NOTICE TO SUBMIT COMMENTS: Anyone may file a statement in support of or in opposition to this proposed amendment with the Missouri Gaming Commission, PO Box 1847, Jefferson City, MO 65102. To be considered, comments must be received within thirty (30) days after publication of this notice in the **Missouri Register**. A public hearing is scheduled for November 17, 2004 at 10:00 a.m. in the Missouri Gaming Commission's Hearing Room, 3417 Knipp Drive, Jefferson City, Missouri.*

**Title 11—DEPARTMENT OF PUBLIC SAFETY
Division 50—Missouri State Highway Patrol
Chapter 2—Motor Vehicle Inspection Division**

PROPOSED AMENDMENT

11 CSR 50-2.311 Bumpers. The division is amending section (4).

PURPOSE: This amendment adds additional height requirements for bumpers on commercial motor vehicles in excess of nine thousand (9,000) pounds.

(4) Inspection Procedure. Inspect motor vehicle bumpers for proper bumper height, mounting, construction and presence of bumpers. (Pickup trucks and other commercial vehicles not equipped by the manufacturer with a rear bumper as standard equipment are not required to be equipped with a rear bumper.) Vehicle design will determine how a vehicle is classified. Passenger cars and station wagons which are designed and manufactured solely as passenger vehicles will be classified as motor vehicles except commercial motor vehicles and must comply with the twenty-two inch (22") maximum bumper height. Motor vehicles designed as multipurpose or utility vehicles, including Broncos, Blazers, Suburbans, Jeeps, vans, minivans, pickups and mini-pickups, will be considered as commercial motor vehicles. The Gross Vehicle Weight Rating (GVWR) of these vehicles will determine the maximum bumper height as specified in the statute. The following chart depicts various bumper configurations and correct locations to measure:

MAXIMUM BUMPER HEIGHTS
(NOT TO SCALE)

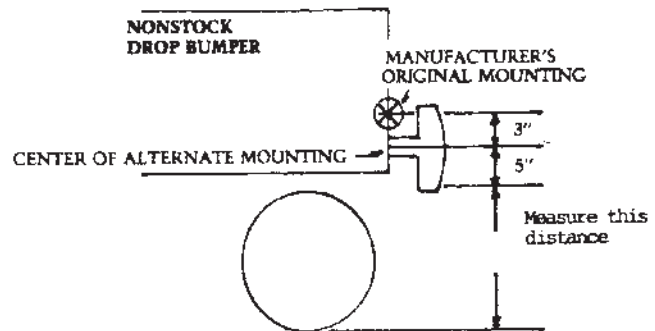
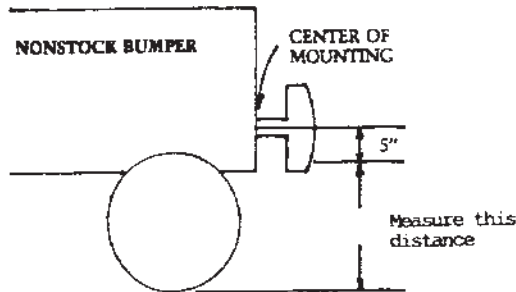
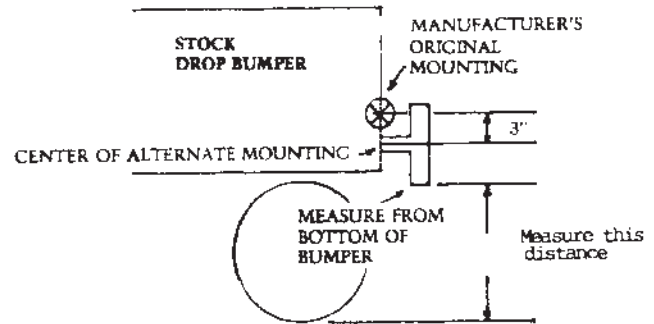
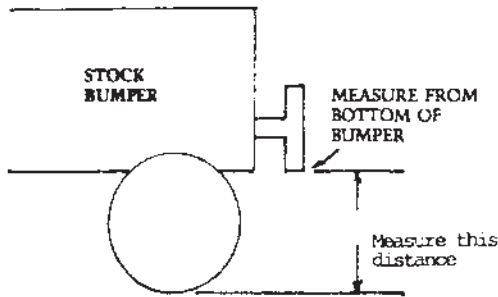

The following bumper heights apply to motor vehicles with a GVWR up through *[nine]* eleven thousand five hundred pounds (*9,000/11,500* lbs.):

| | Maximum Front Bumper Height | Maximum Rear Bumper Height |
|---|-----------------------------|----------------------------|
| Motor vehicles except commercial motor vehicles | 22 inches | 22 inches |
| Commercial motor vehicles (GVWR) | | |
| 4500 lbs. and under | 24 inches | 26 inches |
| 4501 lbs.—7500 lbs. | 27 inches | 29 inches |
| 7501 lbs.—9000 lbs. | 28 inches | 30 inches |
| 9001 lbs.—11500 lbs. | 29 inches | 31 inches |

Department of Public Safety, Missouri State Highway Patrol, PO Box 568, Jefferson City, MO 65102-0568. To be considered, comments must be received within thirty (30) days after publication of this notice in the *Missouri Register*. No public hearing is scheduled.

A motor vehicle will not be rejected for improper bumper height if the motor vehicle was originally equipped by the manufacturer with a bumper that exceeds the stated heights or if the vehicle was originally equipped by the manufacturer with a bumper that fails to comply with subsection (1)(A).

AUTHORITY: section 307.172.2 RSMo [1994] Supp. 2004. Original rule filed July 23, 1986, effective Oct. 27, 1986. For intervening history, please consult the *Code of State Regulations*. Emergency amendment filed Sept. 1, 2004, effective Sept. 11, 2004, expires March 9, 2005. Amended: Filed Sept. 1, 2004.

PUBLIC COST: This proposed amendment will not cost state agencies or political subdivisions more than five hundred dollars (\$500) in the aggregate.

PRIVATE COST: This proposed amendment will not cost private entities more than five hundred dollars (\$500) in the aggregate.

NOTICE TO SUBMIT COMMENTS: Anyone may file a statement in support of or in opposition to this proposed amendment with the

**Title 11—DEPARTMENT OF PUBLIC SAFETY
Division 50—Missouri State Highway Patrol
Chapter 2—Motor Vehicle Inspection Division**

PROPOSED AMENDMENT

11 CSR 50-2.320 School Bus Inspection. The division is adding a new section (22), renumbering the remaining section accordingly and adding a new subsection (23)(K).

PURPOSE: This amendment adds the requirement for the inspection of frames on school buses.

(22) Frame.

(A) Inspect the frame.

(B) Reject any school bus if there are any visible cracks.

[(22)](23) Out-of-Service Criteria. The following items will result in buses being put out-of-service until needed repairs are made. These criteria will be used only by Missouri State Highway Patrol personnel and are not applicable at official inspection stations:

(A) If there is a major exhaust leak in the exhaust system which dumps exhaust in front of the rear axle;

(B) If there are major steering or suspension defects;

(C) If there are major brake defects;

(D) If the stop signal arm is inoperative;

(E) If the front or rear tires have knots or exposed cord or the tread depth is less than four thirty-seconds inch (4/32") on the front tires or less than two thirty-seconds inch (2/32") on the rear tires when measured in any two (2) major grooves at three (3) locations spaced approximately equally around the outside of the tire;

(F) If any emergency door is inoperable from either the inside or outside or any other emergency exit fails to open;

(G) If the red overhead warning flashers are inoperative;

(H) If the one-half inch (1/2") hex nut attached to one (1) end of a one-eighth inch (1/8") drawstring catches on the handrail and lodges between the handrail mounting bracket and the sheet metal body of the bus or the drawstring catches during the handrail drawstring test;

(I) If not equipped with the crossing arm as required or if the crossing arm does not operate when the stop signal arm and overhead warning flashers are activated; *[or]*

(J) If fuel is leaking from any part of the fuel system *./;* or

(K) If the frame has any visible cracks.

AUTHORITY: sections 307.360.2, RSMo 2000 and 307.375, RSMo Supp. [2003] 2004. Original rule filed Nov. 4, 1968, effective Nov. 14, 1968. For intervening history, please consult the Code of State Regulations. Emergency amendment filed Sept. 1, 2004, effective Sept. 11, expires March 9, 2005. Amended: Filed Sept. 1, 2004.

PUBLIC COST: This proposed amendment will not cost state agencies or political subdivisions more than five hundred dollars (\$500) in the aggregate.

PRIVATE COST: This proposed amendment will not cost private entities more than five hundred dollars (\$500) in the aggregate.

NOTICE TO SUBMIT COMMENTS: Anyone may file a statement in support of or in opposition to this proposed amendment with the Department of Public Safety, Missouri State Highway Patrol, PO Box 568, Jefferson City, MO 65102-0568. To be considered, comments must be received within thirty (30) days after publication of this notice in the Missouri Register. No public hearing is scheduled.

**Title 12—DEPARTMENT OF REVENUE
Division 40—State Lottery
Chapter 40—Retail Sales Licenses**

PROPOSED AMENDMENT

12 CSR 40-40.170 Sale During Normal Business Hours. The director is amending section (2).

PURPOSE: This amendment is to ensure it is clear that on-line ticket sales should be interrupted if a customer is not present at the terminal and other customers are waiting in line.

(2) Retailers must give prompt service to lottery customers present and waiting at the terminal to purchase tickets for on-line games. Prompt service includes interrupting processing of on-line ticket orders or sales for which the customer is not present at the terminal.

AUTHORITY: section 313.220, RSMo Supp. [1988] 2003. Original rule filed Sept. 4, 1985, effective Sept. 14, 1985. Amended: Filed Sept. 17, 1992, effective June 7, 1993. Amended: Filed Aug. 24, 2004.

PUBLIC COST: This proposed amendment will not cost state agencies or political subdivisions more than five hundred dollars (\$500) in the aggregate.

PRIVATE COST: This proposed amendment will not cost private entities more than five hundred dollars (\$500) in the aggregate.

NOTICE TO SUBMIT COMMENTS: Anyone may file a statement in support of or in opposition to this proposed amendment with the Missouri Lottery, Terry Skinner, Director of Budget and Planning, PO Box 1603, Jefferson City, MO 65102-1603. To be considered, comments must be received within thirty (30) days after publication of this notice in the Missouri Register. No public hearing is scheduled.

**Title 12—DEPARTMENT OF REVENUE
Division 40—State Lottery
Chapter 40—Retail Sales Licenses**

PROPOSED AMENDMENT

12 CSR 40-40.270 Ticket Transactions in Excess of [\$10,000]/\$5,000. The director is amending the title and section (1).

PURPOSE: This amendment is to reduce the reporting requirement from \$10,000 to \$5,000, and to make the rule apply to any on-line game.

(1) Missouri lottery retailers shall immediately report to the Missouri lottery's director of security transactions in excess of *[ten thousand]* five thousand dollars *[/(\$10,000)]* (\$5,000) for the purchase of lottery tickets for *[an]* any on-line game *[where a jackpot or grand prize has the potential to roll over]*.

AUTHORITY: section 313.220, RSMo Supp. [1988] 2003. Original rule filed Sept. 17, 1992, effective June 7, 1993. Amended: Filed Aug. 24, 2004.

PUBLIC COST: This proposed amendment will not cost state agencies or political subdivisions more than five hundred dollars (\$500) in the aggregate.

PRIVATE COST: This proposed amendment will not cost private entities more than five hundred dollars (\$500) in the aggregate.

NOTICE TO SUBMIT COMMENTS: Anyone may file a statement in support of or in opposition to this proposed amendment with the Missouri Lottery, Terry Skinner, Director of Budget and Planning, PO Box 1603, Jefferson City, MO 65102-1603. To be considered,

comments must be received within thirty (30) days after publication of this notice in the *Missouri Register*. No public hearing is scheduled.

Title 12—DEPARTMENT OF REVENUE
Division 40—State Lottery
Chapter 50—Tickets and Prizes

PROPOSED RULE

12 CSR 40-50.040 Game/Promotion Changes—Cancellation

PURPOSE: This rule gives the executive director of the Missouri lottery the authority to revise or cancel any game or promotion that is found to impugn the security or integrity of the lottery.

(1) The Missouri lottery reserves the right to revise or cancel any game or game related promotion if in the opinion of the executive director such action is necessary to protect the security and/or the integrity of the lottery.

AUTHORITY: section 313.220, RSMo Supp. 2003. Original rule filed Aug. 24, 2004.

PUBLIC COST: This proposed rule will not cost state agencies or political subdivisions more than five hundred dollars (\$500) in the aggregate.

PRIVATE COST: This proposed rule will not cost private entities more than five hundred dollars (\$500) in the aggregate.

NOTICE TO SUBMIT COMMENTS: Anyone may file a statement in support of or in opposition to this proposed rule with the Missouri Lottery, Terry Skinner, Director of Budget and Planning, PO Box 1603, Jefferson City, MO 65102-1603. To be considered, comments must be received within thirty (30) days after publication of this notice in the *Missouri Register*. No public hearing is scheduled.

Title 12—DEPARTMENT OF REVENUE
Division 40—State Lottery
Chapter 85—On-Line Game

PROPOSED AMENDMENT

12 CSR 40-85.170 Game Sell-Out Prohibited. The director is amending section (1).

PURPOSE: This amendment is to change the prevention of buying all number combinations of jackpot games to include all on-line games and promotions.

(1) No Missouri lottery office or Missouri lottery retailer shall directly and knowingly sell a ticket or combination of tickets to any person or entity which would guarantee such a purchaser a [jackpot or grand] prize in an on-line game [where the jackpot or grand prize has the potential to roll over] or on-line game promotion.

AUTHORITY: section 313.220, RSMo Supp. [1988] 2003. Original rule filed Sept. 17, 1992, effective June 7, 1993. Amended: Aug. 24, 2004.

PUBLIC COST: This proposed amendment will not cost state agencies or political subdivisions more than five hundred dollars (\$500) in the aggregate.

PRIVATE COST: This proposed amendment will not cost private entities more than five hundred dollars (\$500) in the aggregate.

NOTICE TO SUBMIT COMMENTS: Anyone may file a statement in support of or in opposition to this proposed amendment with the Missouri Lottery, Terry Skinner, Director of Budget and Planning, PO Box 1603, Jefferson City, MO 65102-1603. To be considered, comments must be received within thirty (30) days after publication of this notice in the *Missouri Register*. No public hearing is scheduled.

Title 15—ELECTED OFFICIALS
Division 30—Secretary of State
Chapter 54—Exemptions and Federal Covered Securities

PROPOSED RESCISSION

15 CSR 30-54.215 Accredited Investor Exemption. This rule exempted offers and sales to accredited investors from the requirements of section 409.3-301 of the Missouri Securities Act of 2003.

PURPOSE: The commissioner of securities is proposing to rescind this rule and adopt a new rule that more clearly describes the accredited investor exemption.

AUTHORITY: sections 409.2-203 and 409.6-605, RSMo Supp. 2003. Original rule filed March 27, 1989, effective June 12, 1989. For intervening history, please consult the *Code of State Regulations*. Emergency rescission filed Sept. 1, 2004, effective Sept. 11, 2004, expires March 9, 2005. Rescinded: Filed Sept. 1, 2004.

PUBLIC COST: This proposed rescission will not cost state agencies or political subdivisions more than five hundred dollars (\$500) in the aggregate.

PRIVATE COST: This proposed rescission will not cost private entities more than five hundred dollars (\$500) in the aggregate.

NOTICE TO SUBMIT COMMENTS: Anyone may file a statement in support of or in opposition to this proposed rescission with the Missouri Secretary of State's Office, Doug Ommen, Commissioner of Securities, 600 West Main Street, Jefferson City, MO 65101. To be considered, comments must be received within thirty (30) days after publication of this notice in the *Missouri Register*. No public hearing is scheduled.

Title 15—ELECTED OFFICIALS
Division 30—Secretary of State
Chapter 54—Exemptions and Federal Covered Securities

PROPOSED RULE

15 CSR 30-54.215 Accredited Investor Exemption

PURPOSE: This rule more clearly describes the exemption of offers and sales to accredited investors from the requirements of sections 409.3-301 and 409.5-504 of the Missouri Securities Act of 2003.

(1) The commissioner, pursuant to the provisions of section 409.2-203 of the Missouri Securities Act of 2003 (the Act), exempts any offer or sale of a security by an issuer in a transaction that meets the requirements of this rule from the requirements of section 409.3-301 and 409.5-504 of the Act. Sales of securities shall be made only to persons who are or the issuer reasonably believes are accredited investors. "Accredited investor" is defined in 17 CFR 230.501(a).

(2) The exemption is not available to an issuer that is in the development state that either has no specific business plan or purpose or has indicated that its business plan is to engage in a merger or acqui-

sition with an unidentified company or companies, or other entity or person.

(3) The issuer reasonably believes that all purchasers are purchasing for investment and not with the view to or for sale in connection with a distribution of the security. Any resale of a security sale in reliance on this exemption within twelve (12) months of sale shall be presumed to be with a view to distribution and not for investment, except a resale pursuant to a registration statement effective under section 490.3-301 of the Act or to an accredited investor pursuant to an exemption available under section 409.2-203 of the Act.

(4) The exemption is not available to an issuer if the issuer, any of the issuer's predecessors, any affiliated issuer, any of the issuer's directors, officers, general partners, beneficial owners of ten percent (10%) or more of any class of its equity securities, any of the issuer's promoters presently connected with the issuer in any capacity, any underwriter of the securities to be offered, or any partner, director or officer of such underwriter:

(A) Within the last five (5) years, has filed a registration statement which is the subject of a currently effective registration stop order entered by any state securities administrator or the United States Securities and Exchange Commission;

(B) Within the last five (5) years, has been convicted of any criminal offense in connection with the offer, purchase or sale of any security, or involving fraud or deceit;

(C) Is currently subject to any state or federal administrative enforcement order or judgment, entered within the last five (5) years, finding fraud or deceit in connection with the purchase or sale of any security; or

(D) Is currently subject to any order, judgment or decree of any court of competent jurisdiction, entered within the last five (5) years, temporarily, preliminarily or permanently restraining or enjoining such party from engaging in or continuing to engage in any conduct or practice involving fraud or deceit in connection with the purchase or sale of any security.

(5) Section (4) shall not apply if:

(A) The party subject to the disqualification is licensed or registered to conduct securities related business in the state in which the order, judgment or decree creating the disqualification was entered against such party;

(B) Before the first offer under this exemption, the state securities administrator, or the court or regulatory authority that entered the order, judgment, or decree, waives the disqualification; or

(C) The issuer establishes that it did not know and in the exercise of reasonable care, based on a factual inquiry, could not have known that a disqualification existed under this section.

(6) A general announcement of the proposed offering may be made by any means.

(7) The general announcement shall include only the following information, unless additional information is specifically permitted by the commissioner:

(A) The name, address and telephone number of the issuer of the securities;

(B) The name, a brief description and price (if known) of any security to be issued;

(C) A brief description of the business of the issuer in twenty-five (25) words or less;

(D) The type, number and aggregate amount of securities being offered;

(E) The name, address and telephone number of the person to contact for additional information; and

(F) A statement that:

1. Sales will only be made to accredited investors;

2. No money or other consideration is being solicited or will be accepted by way of this general announcement; and

3. The securities have not been registered with or approved by any state securities agency or the U.S. Securities and Exchange Commission and are being offered and sold pursuant to an exemption from registration.

(8) The issuer, in connection with an offer, may provide information in addition to the general announcement under section (7), if such information:

(A) Is delivered through an electronic database that is restricted to persons who have been prequalified as accredited investors; or

(B) Is delivered after the issuer reasonably believes that the prospective purchaser is an accredited investor.

(9) No telephone solicitation shall be permitted unless prior to placing the call, the issuer reasonably believes that the prospective purchaser to be solicited is an accredited investor.

(10) Dissemination of the general announcement of the proposed offering to persons who are not accredited investors shall not disqualify the issuer from claiming the exemption under this rule.

(11) The issuer shall file with the securities division a notice of transaction, a consent to service of process, a copy of the general announcement, and a registration fee in compliance with section 409.3-305(b) within fifteen (15) days after the first sale in this state.

AUTHORITY: sections 409.2-203 and 409.6-605, RSMo Supp. 2003. Original rule filed March 27, 1989, effective June 12, 1989. For intervening history, please consult the Code of State Regulations. Emergency rescission and rule filed Sept. 1, 2004, effective Sept. 11, 2004, expires March 9, 2005. Rescinded and readopted: Filed Sept. 1, 2004.

PUBLIC COST: This proposed rule will not cost state agencies or political subdivisions more than five hundred dollars (\$500) in the aggregate.

PRIVATE COST: This proposed rule will not cost private entities more than five hundred dollars (\$500) in the aggregate.

NOTICE TO SUBMIT COMMENTS: Anyone may file a statement in support of or in opposition to this proposed rule with the Missouri Secretary of State's Office, Doug Ommen, Commissioner of Securities, 600 West Main Street, Jefferson City, MO 65101. To be considered, comments must be received within thirty (30) days after publication of this notice in the Missouri Register. No public hearing is scheduled.

Title 16—RETIREMENT SYSTEMS

Division 50—The County Employees' Retirement Fund Chapter 10—County Employees' Defined Contribution Plan

PROPOSED AMENDMENT

16 CSR 50-10.050 Distribution of Accounts. The board is amending the title of section (3), amending subsection (3)(A) and adding new subsections (3)(E) and (F).

PURPOSE: This amendment amends the timing and form of benefit payments from the defined contribution plan.

(3) Commencement of Distributions and Payment Options.

(A) General Rule. Distribution of a Participant's Account under the Plan shall be made in [a single sum] the form elected by the Participant, commencing as soon as administratively feasible after

the Participant's Separation from Service occurs, unless the Participant elects to defer this payment. A Participant may elect that the [single-sum] distribution of benefits be made at any time following his or her Separation from Service as long as distributions commence no later than sixty (60) days following the date on which the Participant attains age seventy and one-half (70) 1/2, or retires, if later.

(E) **Payment Options.** A Participant's election of a payment option must be made at least thirty (30) days prior to the date that the payment of benefits is to commence. If a timely election of a payment option is not made, benefits shall be paid in a single lump sum. Once payments have commenced, the form of payment option may not be changed.

(F) Subject to applicable law and the other provisions of this Plan, distributions may be made in accordance with one (1) of the following payment options:

1. A single lump-sum payment;
2. Installment payments for a period of years (payable on a monthly, quarterly, semi-annual, or annual basis) which extends no longer than the life expectancy of the Participant;
3. Partial lump-sum payment of a designated amount, with the balance payable in installment payments for a period of years, as described in paragraph (3)(F)2., as long as such installment payments begin prior to the end of the calendar year following the year the partial lump-sum payment was made; and
4. Annuity payments (payable on a monthly, quarterly, or annual basis) for the lifetime of the Participant or for the lifetimes of the Participant and Beneficiary if permitted under section 401(a)(9) of the Code.

AUTHORITY: sections 50.1250, RSMo Supp. [2003] and 50.1260, RSMo 2000. Original rule filed May 9, 2000, effective Jan. 30, 2001. Amended: Filed April 25, 2002, effective Nov. 30, 2002. Amended: Filed Aug. 24, 2004.

PUBLIC COST: This proposed amendment will not cost state agencies or political subdivisions more than five hundred dollars (\$500) in the aggregate.

PRIVATE COST: This proposed amendment will not cost private entities more than five hundred dollars (\$500) in the aggregate.

NOTICE TO SUBMIT COMMENTS: Anyone may file a statement in support of or in opposition to this proposed amendment with the County Employees' Retirement Fund, PO Box 2271, Jefferson City, MO 65102. To be considered, comments must be received within thirty (30) days after publication of this notice in the *Missouri Register*. No public hearing is scheduled.

This section will contain the final text of the rules proposed by agencies. The order of rulemaking is required to contain a citation to the legal authority upon which the order of rulemaking is based; reference to the date and page or pages where the notice of proposed rulemaking was published in the *Missouri Register*; an explanation of any change between the text of the rule as contained in the notice of proposed rulemaking and the text of the rule as finally adopted, together with the reason for any such change; and the full text of any section or subsection of the rule as adopted which has been changed from that contained in the notice of proposed rulemaking. The effective date of the rule shall be not less than thirty (30) days after the date of publication of the revision to the *Code of State Regulations*.

The agency is also required to make a brief summary of the general nature and extent of comments submitted in support of or opposition to the proposed rule and a concise summary of the testimony presented at the hearing, if any, held in connection with the rulemaking, together with a concise summary of the agency's findings with respect to the merits of any such testimony or comments which are opposed in whole or in part to the proposed rule. The ninety (90)-day period during which an agency shall file its Order of Rulemaking for publication in the *Missouri Register* begins either: 1) after the hearing on the Proposed Rulemaking is held; or 2) at the end of the time for submission of comments to the agency. During this period, the agency shall file with the secretary of state the order of rulemaking, either putting the proposed rule into effect, with or without further changes, or withdrawing the proposed rule.

**Title 3—DEPARTMENT OF CONSERVATION
Division 10—Conservation Commission
Chapter 7—Wildlife Code: Hunting: Seasons,
Methods, Limits**

ORDER OF RULEMAKING

By the authority vested in the Conservation Commission under sections 40 and 45 of Art. IV, Mo. Const., the commission amends a rule as follows:

3 CSR 10-7.440 is amended.

This amendment establishes hunting seasons and limits and is excepted by section 536.021, RSMo from the requirement for filing as a proposed amendment.

The Department of Conservation amended 3 CSR 10-7.440 by establishing seasons and limits for hunting migratory waterfowl during the 2004–2005 seasons.

3 CSR 10-7.440 Migratory Game Birds and Waterfowl: Seasons, Limits

PURPOSE: This amendment establishes season dates and bag limits for hunting waterfowl within frameworks established by the U.S. Fish and Wildlife Service for the 2004–2005 seasons.

(1) Migratory game birds and waterfowl may be taken, possessed, transported and stored as provided in federal regulations. The head or one (1) fully feathered wing must remain attached to all waterfowl while being transported from the field to one's home or a commercial preservation facility. Seasons and limits are as follows:

(F) Ducks (except for canvasback and pintail) and coots may be taken from one-half (1/2) hour before sunrise to sunset from October 30 through December 28 in the North Zone (that portion of Missouri north of a line running west from the Illinois border at Lock and Dam 25; west on Lincoln County Hwy. N to Mo. Hwy. 79; south on Mo. Hwy. 79 to Mo. Hwy. 47; west on Mo. Hwy. 47 to Interstate Hwy. 70; west on Interstate Hwy. 70 to U.S. Hwy. 54; south on U.S. Hwy. 54 to U.S. Hwy 50; and west on U.S. Hwy. 50 to the Kansas border); from November 26 through January 24 in the South Zone (that portion of the state south of a line running west from the Illinois border on Mo. Hwy. 34 to Interstate Hwy. 55; south on Interstate Hwy. 55 to U.S. Hwy. 62; west on U.S. Hwy. 62 to Mo. Hwy. 53; north on Mo. Hwy. 53 to Mo. Hwy. 51; north on Mo. Hwy. 51 to U.S. Hwy. 60; west on U.S. Hwy. 60 to Mo. Hwy. 21; north on Mo. Hwy. 21 to Mo. Hwy. 72; west on Mo. Hwy. 72 to Mo. Hwy. 32; west on Mo. Hwy. 32 to U.S. Hwy. 65; north on U.S. Hwy. 65 to U.S. Hwy. 54; west on U.S. Hwy. 54 to the Kansas border); and from November 6 through January 4 in the Middle Zone (remainder of Missouri). Pintails and canvasbacks may be taken from October 30 through November 28 in the North Zone, November 6 through December 5 in the Middle Zone, and November 26 through December 25 in the South Zone. Ducks and coots may be taken by youth hunters fifteen (15) years of age or younger from one-half (1/2) hour before sunrise to sunset from October 23 through October 24 in the North Zone, from October 30 through October 31 in the Middle Zone and from November 20 through November 21 in the South Zone. Youth hunters must be accompanied by an adult eighteen (18) years of age or older who cannot hunt ducks. Adults must be licensed unless the youth hunter possesses a valid hunter education certificate card. Limits are as follows:

1. Coots—Fifteen (15) daily; thirty (30) in possession.

2. Ducks—The daily bag limit of ducks is six (6) and may include no more than four (4) mallards (no more than two (2) of which may be a female), three (3) scaup, two (2) wood ducks, one (1) black duck, two (2) redheads, one (1) hooded merganser, one (1) pintail and one (1) canvasback (during the prescribed season and during the youth hunts). The possession limit is twelve (12), including no more than eight (8) mallards (no more than four (4) of which may be female), six (6) scaup, four (4) wood ducks, two (2) black ducks, four (4) redheads, two (2) hooded mergansers, two (2) canvasbacks and two (2) pintails.

(G) Geese may be taken from one-half (1/2) hour before sunrise to sunset as follows:

1. Blue, snow, and Ross's geese may be taken from October 30 through January 24 in the North Zone, and from November 6 through January 30 in the Middle Zone, Southeast Zone and South Zone.

2. White-fronted geese may be taken from October 30 through January 23 in the North Zone, and from November 6 through January 30 in the Middle Zone, Southeast Zone and South Zone.

3. Canada geese and brant may be taken from September 25 through October 11, October 30 through November 28 and December 26 through January 24 in the North Zone; from September 25 through October 14, November 6 through November 30, and January 1 through January 30 in the Middle Zone (except the Southeast Zone); and from October 2 through October 12, and November 26 through January 30 in the Southeast Zone and the South Zone.

4. The daily bag limit is twenty (20) blue, snow or Ross's geese, one (1) brant and two (2) white-fronted geese statewide. The possession limit for brant is two (2) and for white-fronted geese four (4) each, and there is no possession limit for blue, snow and Ross's geese.

5. In the North Zone the daily bag limit is three (3) Canada geese from September 25 through October 11, two (2) Canada geese from October 30 through November 28, and one (1) Canada goose

from December 26 through January 24. The possession limit is six (6) Canada geese from September 25 through October 11, four (4) Canada geese from October 30 through November 28, and two (2) Canada geese thereafter. In the Middle Zone the daily bag limit is three (3) Canada geese from September 25 through October 14, two (2) Canada geese from November 6 through November 30, and one (1) Canada goose from January 1 through January 30. The possession limit is six (6) Canada geese from September 25 through October 14, four (4) Canada geese from November 6 through November 30, and two (2) Canada geese from January 1 through January 30. In the South Zone and Southeast Zone, the daily bag limit is three (3) Canada geese from October 2 through October 12 and two (2) Canada geese thereafter. The possession limit is six (6) Canada geese from October 2 through October 12 and four (4) Canada geese thereafter.

6. Geese may be taken by youth hunters in the North Zone from October 23 through October 24, in the Middle Zone from October 30 through October 31, and in the South Zone from November 20 through November 21. The daily bag limit is twenty (20) blue, snow, and Ross's geese, two (2) white-fronted geese, one (1) brant, and two (2) Canada geese. The possession limit for brant is two (2), and for white-fronted geese and Canada geese is four (4) each and there is no possession limit for blue, snow, and Ross's geese.

7. Zones: The North Zone shall be that portion of the state north of a line running west from the Illinois border at Lock and Dam 25; west on Lincoln County Hwy. N to Mo. Hwy. 79; south on Mo. Hwy. 79 to Mo. Hwy. 47; west on Mo. Hwy. 47 to Interstate Hwy. 70; west on Interstate Hwy. 70 to U.S. Hwy. 54; south on U.S. Hwy. 54 to U.S. Hwy. 50; west on U.S. Hwy. 50 to the Kansas border. The South Zone shall be that portion of Missouri south of a line running west from the Illinois border on Mo. Hwy. 34 to Interstate Hwy. 55; south on Interstate Hwy. 55 to U.S. Hwy. 62; west on U.S. Hwy. 62 to Mo. Hwy. 53; north on Mo. Hwy. 53 to Mo. Hwy. 51; north on Mo. Hwy. 51 to U.S. Hwy. 60; west on U.S. Hwy. 60 to Mo. Hwy. 21; north on Mo. Hwy. 21 to Mo. Hwy. 72; west on Mo. Hwy. 72 to Mo. Hwy. 32; west on Mo. Hwy. 32 to U.S. Hwy. 65; north on U.S. Hwy. 65 to U.S. Hwy. 54; west on U.S. Hwy. 54 to the Kansas border. The Middle Zone shall be the remainder of Missouri excluding the Southeast Zone (that portion of the state west of a line beginning at the intersection of Mo. Hwy. 34 and Interstate Hwy. 55, south of Interstate Hwy. 55 to U.S. Hwy. 62; west on U.S. Hwy. 62 to Mo. Hwy. 53; north on Mo. Hwy. 53 to Mo. Hwy. 51; north on Mo. Hwy. 51 to U.S. Hwy. 60; west on U.S. Hwy. 60 to Mo. Hwy. 21; north on Mo. Hwy. 21 to Mo. Hwy. 72; east on Mo. Hwy. 72 to Mo. Hwy. 34; east on Mo. Hwy. 34 to Interstate Hwy. 55).

(I) The hunting season for blue, snow and Ross's geese closes on January 24, 2005 in the North Zone and on January 30, 2005 in the Middle Zone, Southeast Zone and South Zone in order to implement a light goose Conservation Order.

1. Persons who possess a valid migratory bird permit may chase, pursue, and take blue, snow and Ross's geese between the hours of one-half (1/2) hour before sunrise to one-half (1/2) hour after sunset from January 25 through April 30, 2005 in the North Zone and from January 31 through April 30, 2005 in the Middle Zone, Southeast Zone and South Zone. Any other regulation notwithstanding, methods for the taking of blue, snow and Ross's geese include using shotguns capable of holding more than three (3) shells, and with the use or aid of recorded or electrically amplified bird calls or sounds, or recorded or electrically amplified imitations of bird calls or sounds. Exceptions to the above permit requirement include landowners or lessees, as described in this code, and persons fifteen (15) years of age or younger, provided s/he is in the immediate presence of a properly licensed adult or has in his/her possession a valid hunter education certificate card. A daily bag limit will not be in effect January 25 through April 30 in the North Zone and from January 31 through April 30 in the Middle Zone, Southeast Zone, and South Zone.

SUMMARY OF COMMENTS: Seasons and limits are excepted from the requirement of filing as a proposed amendment under section 536.021, RSMo.

This amendment filed August 30, 2004 effective **September 10, 2004**.

**Title 3—DEPARTMENT OF CONSERVATION
Division 10—Conservation Commission
Chapter 7—Wildlife Code: Hunting: Seasons, Methods,
Limits**

ORDER OF RULEMAKING

By the authority vested in the Conservation Commission under sections 40 and 45 of Art. IV, Mo. Const., the commission amends a rule as follows:

3 CSR 10-7.450 Furbearers: Hunting Seasons, Methods is amended.

A notice of proposed rulemaking containing the text of the proposed amendment was published in the *Missouri Register* on July 15, 2004 (29 MoReg 1091). No changes have been made in the text of the proposed amendment, so it is not reprinted here. This proposed amendment becomes effective thirty (30) days after publication in the *Code of State Regulations*.

SUMMARY OF COMMENTS: No comments were received.

**Title 3—DEPARTMENT OF CONSERVATION
Division 10—Conservation Commission
Chapter 9—Wildlife Code: Confined Wildlife: Privileges,
Permits, Standards**

ORDER OF RULEMAKING

By the authority vested in the Conservation Commission under sections 40 and 45 of Art. IV, Mo. Const., the commission amends a rule as follows:

3 CSR 10-9.442 is amended.

This amendment establishes hunting seasons and limits and is excepted by section 536.021, RSMo from the requirement for filing as a proposed amendment.

The Department of Conservation amended 3 CSR 10-9.442 by adjusting the season for waterfowl hunting by falconers in 2004–2005 to conform to federal frameworks.

3 CSR 10-9.442 Falconry

PURPOSE: This amendment adjusts the season dates for hunting waterfowl by falconry for the 2004–2005 season as provided in the frameworks established by the U.S. Fish and Wildlife Service.

(2) Only designated types and numbers of birds of prey may be possessed and all these birds shall bear a numbered, nonreusable marker provided by the department. Birds held under a falconry permit may be used, without further permit, to pursue and take wildlife within the following seasons and bag limits:

(E) Ducks, mergansers and coots may be taken from one-half (1/2) hour before sunrise to sunset as follows: in the North Zone, September 11 through September 19 and September 25 through December 28; in the Middle Zone, September 11 through September 19 and September 29 through January 4; and, in the South Zone, September 11 through September 19 and October 19 through January

24. Daily limit: three (3) birds singly or in the aggregate, including doves; possession limit: six (6) birds singly or in the aggregate, including doves.

SUMMARY OF COMMENTS: Seasons and limits are excepted from the requirement of filing as a proposed amendment under section 536.021, RSMo.

This amendment filed August 30, 2004 effective **September 10, 2004**.

**Title 3—DEPARTMENT OF CONSERVATION
Division 10—Conservation Commission
Chapter 11—Wildlife Code: Special Regulations for
Department Areas**

ORDER OF RULEMAKING

By the authority vested in the Conservation Commission under sections 40 and 45 of Art. IV, Mo. Const., the commission amends a rule as follows:

3 CSR 10-11.186 Waterfowl Hunting is **amended**.

A notice of proposed rulemaking containing the text of the proposed amendment was published in the *Missouri Register* on July 15, 2004 (29 MoReg 1091-1092). No changes have been made in the text of the proposed amendment, so it is not reprinted here. This proposed amendment becomes effective thirty (30) days after publication in the *Code of State Regulations*.

SUMMARY OF COMMENTS: No comments were received.

**Title 3—DEPARTMENT OF CONSERVATION
Division 10—Conservation Commission
Chapter 12—Wildlife Code: Special Regulations for Areas
Owned by Other Entities**

ORDER OF RULEMAKING

By the authority vested in the Conservation Commission under sections 40 and 45 of Art. IV, Mo. Const., the commission amends a rule as follows:

3 CSR 10-12.130 Fishing, General Provisions and Seasons is **amended**.

A notice of proposed rulemaking containing the text of the proposed amendment was published in the *Missouri Register* on July 15, 2004 (29 MoReg 1092). No changes have been made in the text of the proposed amendment, so it is not reprinted here. This proposed amendment becomes effective thirty (30) days after publication in the *Code of State Regulations*.

SUMMARY OF COMMENTS: No comments were received.

**Title 3—DEPARTMENT OF CONSERVATION
Division 10—Conservation Commission
Chapter 12—Wildlife Code: Special Regulations for Areas
Owned by Other Entities**

ORDER OF RULEMAKING

By the authority vested in the Conservation Commission under sections 40 and 45 of Art. IV, Mo. Const., the commission amends a rule as follows:

3 CSR 10-12.140 Fishing, Daily and Possession Limits is **amended**.

A notice of proposed rulemaking containing the text of the proposed amendment was published in the *Missouri Register* on July 15, 2004 (29 MoReg 1092). No changes have been made in the text of the proposed amendment, so it is not reprinted here. This proposed amendment becomes effective thirty (30) days after publication in the *Code of State Regulations*.

SUMMARY OF COMMENTS: No comments were received.

**Title 3—DEPARTMENT OF CONSERVATION
Division 10—Conservation Commission
Chapter 12—Wildlife Code: Special Regulations for Areas
Owned by Other Entities**

ORDER OF RULEMAKING

By the authority vested in the Conservation Commission under sections 40 and 45 of Art. IV, Mo. Const., the commission adopts a rule as follows:

3 CSR 10-12.155 Fishing, Stone Mill Spring Branch is **adopted**.

A notice of proposed rulemaking containing the text of the proposed rule was published in the *Missouri Register* on July 15, 2004 (29 MoReg 1092-1093). No changes have been made in the text of the proposed rule, so it is not reprinted here. This proposed rule becomes effective thirty (30) days after publication in the *Code of State Regulations*.

SUMMARY OF COMMENTS: No comments were received.

**Title 3—DEPARTMENT OF CONSERVATION
Division 10—Conservation Commission
Chapter 20—Wildlife Code: Definitions**

ORDER OF RULEMAKING

By the authority vested in the Conservation Commission under sections 40 and 45 of Art. IV, Mo. Const., the commission amends a rule as follows:

3 CSR 10-20.805 Definitions is **amended**.

A notice of proposed rulemaking containing the text of the proposed amendment was published in the *Missouri Register* on July 15, 2004 (29 MoReg 1093). No changes have been made in the text of the proposed amendment, so it is not reprinted here. This proposed amendment becomes effective thirty (30) days after publication in the *Code of State Regulations*.

SUMMARY OF COMMENTS: No comments were received.

**Title 4—DEPARTMENT OF ECONOMIC
DEVELOPMENT
Division 240—Public Service Commission
Chapter 3—Filing and Reporting Requirements**

ORDER OF RULEMAKING

By the authority vested in the Public Service Commission under section 386.250, RSMo 2000, the commission amends a rule as follows:

4 CSR 240-3.020 Filing Requirements Regarding Utility Company Name Changes is amended.

A notice of proposed rulemaking containing the text of the proposed amendment was published in the *Missouri Register* on May 3, 2004 (29 MoReg 717). No changes have been made in the text of the proposed amendment, so it is not reprinted here. This proposed amendment becomes effective thirty (30) days after publication in the *Code of State Regulations*.

SUMMARY OF COMMENTS: The written public comment period ended June 2, 2004, and the commission held a public hearing on this proposed amendment on June 4, 2004. The commission's staff filed comments and testified at the public hearing generally in support of the amendment. Counsel from the Office of the Public Counsel testified generally in support of the amendment.

RESPONSE: No changes have been made to the amendment as a result of the general comments. The commission has previously found that this rule amendment is necessary to carry out the purposes of section 386.250, RSMo.

**Title 4—DEPARTMENT OF ECONOMIC
DEVELOPMENT
Division 240—Public Service Commission
Chapter 3—Filing and Reporting Requirements**

ORDER OF RULEMAKING

By the authority vested in the Public Service Commission under section 386.250, RSMo 2000, the commission amends a rule as follows:

4 CSR 240-3.510 is amended.

A notice of proposed rulemaking containing the text of the proposed amendment was published in the *Missouri Register* on May 3, 2004 (29 MoReg 717-718). Changes have been made to the authority section which is reprinted here. This proposed amendment becomes effective thirty (30) days after publication in the *Code of State Regulations*.

SUMMARY OF COMMENTS: The written public comment period ended June 2, 2004, and the commission held a public hearing on this proposed amendment on June 4, 2004. Natelle Dietrich of the commission's staff filed comments and testified at the public hearing generally in support of the amendment. Counsel from the Office of the Public Counsel testified generally in support of the amendment. **RESPONSE:** No changes have been made to the amendment as a result of the general comments. The commission has previously found that this rule amendment is necessary to carry out the purposes of sections 386.250, 392.450, 392.451 and 392.455, RSMo.

COMMENT: In her written comments, Natelle Dietrich of the commission's staff noted that the Legislature has explicitly authorized requirements of the nature enacted by this amended rule at sections 392.450, 392.451 and 392.455, RSMo. Accordingly, she recommended referencing these sections in the authority section of the rule. **RESPONSE AND EXPLANATION OF CHANGE:** The commission will add these statutory references to the authority section of the rule.

4 CSR 240-3.510 Filing Requirements for Telecommunications Company Applications for Certificates of Service Authority to Provide Telecommunications Services, Whether Interexchange, Local Exchange or Basic Local Exchange

AUTHORITY: sections 386.250, 392.450, 392.451 and 392.455, RSMo 2000. Original rule filed Aug. 16, 2002, effective April 30, 2003. Amended: Filed March 19, 2004.

**Title 4—DEPARTMENT OF ECONOMIC
DEVELOPMENT
Division 240—Public Service Commission
Chapter 3—Filing and Reporting Requirements**

ORDER OF RULEMAKING

By the authority vested in the Public Service Commission under section 386.250, RSMo 2000, the commission amends a rule as follows:

4 CSR 240-3.520 Filing Requirements for Telecommunications Company Applications for Authority to Sell, Assign, Lease or Transfer Assets is amended.

A notice of proposed rulemaking containing the text of the proposed amendment was published in the *Missouri Register* on May 3, 2004 (29 MoReg 718-720). No changes have been made in the text of the proposed amendment, so it is not reprinted here. This proposed amendment becomes effective thirty (30) days after publication in the *Code of State Regulations*.

SUMMARY OF COMMENTS: The written public comment period ended June 2, 2004, and the commission held a public hearing on this proposed amendment on June 4, 2004. Natelle Dietrich of the commission's staff filed comments and testified at the public hearing generally in support of the amendment. Counsel from the Office of the Public Counsel testified generally in support of the amendment. **RESPONSE:** No changes have been made to the amendment as a result of the general comments. The commission has previously found that this rule amendment is necessary to carry out the purposes of sections 386.250, RSMo.

**Title 4—DEPARTMENT OF ECONOMIC
DEVELOPMENT
Division 240—Public Service Commission
Chapter 3—Filing and Reporting Requirements**

ORDER OF RULEMAKING

By the authority vested in the Public Service Commission under section 386.250, RSMo 2000, the commission amends a rule as follows:

4 CSR 240-3.525 Filing Requirements for Telecommunications Company Applications for Authority to Merge or Consolidate is amended.

A notice of proposed rulemaking containing the text of the proposed amendment was published in the *Missouri Register* on May 3, 2004 (29 MoReg 721-723). No changes have been made in the text of the proposed amendment, so it is not reprinted here. This proposed amendment becomes effective thirty (30) days after publication in the *Code of State Regulations*.

SUMMARY OF COMMENTS: The written public comment period ended June 2, 2004, and the commission held a public hearing on this proposed amendment on June 4, 2004. Natelle Dietrich of the commission's staff filed comments and testified at the public hearing generally in support of the amendment. Counsel from the Office of the Public Counsel testified generally in support of the amendment. **RESPONSE:** No changes have been made to the amendment as a result of the general comments. The commission has previously found that this rule amendment is necessary to carry out the purposes of section 386.250, RSMo.

**Title 4—DEPARTMENT OF ECONOMIC
DEVELOPMENT
Division 240—Public Service Commission
Chapter 3—Filing and Reporting Requirements**

ORDER OF RULEMAKING

By the authority vested in the Public Service Commission under section 386.250, RSMo 2000, the commission amends a rule as follows:

4 CSR 240-3.530 Filing Requirements for Telecommunications Company Applications for Authority to Issue Stock, Bonds, Notes and Other Evidences of Indebtedness is **amended**.

A notice of proposed rulemaking containing the text of the proposed amendment was published in the *Missouri Register* on May 3, 2004 (29 MoReg 724-726). No changes have been made in the text of the proposed amendment, so it is not reprinted here. This proposed amendment becomes effective thirty (30) days after publication in the *Code of State Regulations*.

SUMMARY OF COMMENTS: The written public comment period ended June 2, 2004, and the commission held a public hearing on this proposed rule on June 4, 2004. Natelle Dietrich on behalf of the commission's staff filed comments and testified at the public hearing in support of the proposed amendment. Mimi MacDonald, counsel for Southwestern Bell Telephone, LP d/b/a SBC Missouri, filed written comments and testified at the public hearing in this proceeding but made no specific comments directed to this proposed amendment. Michael Dandino of the Office of the Public Counsel testified at the public hearing, generally in support of the proposed amendment.

RESPONSE: No change to this section will be made as a result of the general comments.

Title 4—DEPARTMENT OF ECONOMIC DEVELOPMENT Division 240—Public Service Commission Chapter 3—Filing and Reporting Requirements

ORDER OF RULEMAKING

By the authority vested in the Public Service Commission under section 386.250, RSMo 2000, the commission withdraws a proposed amendment as follows:

4 CSR 240-3.535 Filing Requirements for Telecommunications Company Applications for Authority to Acquire the Stock of a Public Utility is **withdrawn**.

A notice of proposed rulemaking containing the text of the proposed amendment was published in the *Missouri Register* on May 3, 2004 (29 MoReg 727-729). This proposed amendment is withdrawn.

SUMMARY OF COMMENTS: The written public comment period ended June 2, 2004, and the commission held a public hearing on this proposed amendment on June 4, 2004. Natelle Dietrich on behalf of the commission's staff filed comments and testified at the public hearing about the proposed amendment. Mimi MacDonald, counsel for Southwestern Bell Telephone, LP d/b/a SBC Missouri (SBC), filed written comments and testified on the proposed amendment at the public hearing. SBC, in its written comments, noted that it appears the commission is creating an exemption for competitive local exchange companies with the proposed amendment. During the public hearing, Natelle Dietrich, on behalf of the commission's staff, testified that there appeared to be confusion when the rule was transferred from its former location in Chapter 2 into its current location in Chapter 3. Ms. Dietrich recommended that no change be made to the existing rule.

RESPONSE: The commission has considered the comments and agrees that the intent of the proposed rule was not to create exemptions for competitive telecommunications companies. The existing

rule should not be amended. As a result, the commission is withdrawing this rulemaking.

Title 4—DEPARTMENT OF ECONOMIC DEVELOPMENT Division 240—Public Service Commission Chapter 3—Filing and Reporting Requirements

ORDER OF RULEMAKING

By the authority vested in the Public Service Commission under section 386.250, RSMo 2000, the commission adopts a rule as follows:

4 CSR 240-3.560 is adopted.

A notice of proposed rulemaking containing the text of the proposed rule was published in the *Missouri Register* on May 3, 2004 (29 MoReg 730). Those sections with changes are reprinted here. This proposed rule becomes effective thirty (30) days after publication in the *Code of State Regulations*.

SUMMARY OF COMMENTS: The written public comment period ended June 2, 2004, and the commission held a public hearing on this proposed rule on June 4, 2004. Natelle Dietrich on behalf of the commission's staff filed comments and testified at the public hearing in support of the proposed rule. Mimi MacDonald, counsel for Southwestern Bell Telephone, LP d/b/a SBC Missouri (SBC), filed written comments and testified on the proposed rule at the public hearing. Michael Dandino of the Office of the Public Counsel testified at the public hearing generally in support of the proposed rule.

COMMENT: Mimi MacDonald of SBC, in her written comments, noted that it appears the intent of the rule was to establish procedures for telecommunications companies that cease to provide basic local service or interexchange service and sought clarification that the rule does not apply each time a company ceases offering an individual service product. She suggested a modification to the language to provide this clarification. During the public hearing, Natelle Dietrich, on behalf of staff, testified in support of SBC's suggested language change, which clarifies that the rule applies to companies that cease providing basic local or interexchange telecommunications service in Missouri or certain Missouri exchanges.

RESPONSE AND EXPLANATION OF CHANGE: The commission has considered the comments and agrees that the applicability of the proposed rule should be clarified. The proposed rule will be modified as suggested by SBC and supported by staff. The proposed rule will be further modified to include a thirty (30)-day time frame as to the applicability of the proposed rule.

4 CSR 240-3.560 Telecommunications Procedure for Ceasing Operations

(1) All telecommunications companies ceasing operation in Missouri or discontinuing basic local or interexchange telecommunications service to any geographic service area within the state shall provide to the commission at least thirty (30) days prior to cessation or discontinuance:

Title 4—DEPARTMENT OF ECONOMIC DEVELOPMENT Division 240—Public Service Commission Chapter 3—Filing and Reporting Requirements

ORDER OF RULEMAKING

By the authority vested in the Public Service Commission under section 386.250, RSMo 2000, the commission adopts a rule as follows:

4 CSR 240-3.565 is adopted.

A notice of proposed rulemaking containing the text of the proposed rule was published in the *Missouri Register* on May 3, 2004 (29 MoReg 730-731). Those sections with changes are reprinted here. This proposed rule becomes effective thirty (30) days after publication in the *Code of State Regulations*.

SUMMARY OF COMMENTS: The written public comment period ended June 2, 2004, and the commission held a public hearing on this proposed rule on June 4, 2004. Natelle Dietrich on behalf of the commission's staff filed comments and testified at the public hearing in support of the proposed rule. Mimi MacDonald, counsel for Southwestern Bell Telephone, LP d/b/a SBC Missouri (SBC), filed written comments and testified on the proposed rule. Michael Dandino of the Office of the Public Counsel testified at the public hearing generally in support of the proposed rule.

COMMENT: Mimi MacDonald, in SBC's written comments, questioned the requirement that a telecommunications company report on the bankruptcy of an affiliate. SBC stated that if the affiliate is a telecommunications provider in Missouri, the proposed rule requires the affiliate to provide notice. SBC went on to state that if the affiliate is not a telecommunications provider in Missouri, there is no need to advise the commission of the bankruptcy, unless it is the parent company of a competitive local exchange carrier that files for bankruptcy. At the public hearing, there were many commission questions concerning the definition of "affiliate." SBC proposed alternative language changing "affiliate" to "parent" or "parent of its parent." SBC expresses concern that the commission would be "inundated" with paperwork depending upon the definition.

RESPONSE AND EXPLANATION OF CHANGE: Since the proposed rule only requires companies to provide to the commission: a notice that the company or an affiliate has filed bankruptcy; the bankruptcy case number, the bankruptcy filing date; the bankruptcy chapter number; and the bankruptcy court, the commission does not find this information burdensome or requiring large amounts of paperwork to be provided to the commission. However, the proposed rule will be further clarified so that only one certificated telecommunications company affiliate need provide the information.

COMMENT: Mimi MacDonald of SBC, in SBC's written comments, suggested section (1) of the proposed rule be modified to require a telecommunications company that files bankruptcy to "immediately" notify the commission.

RESPONSE AND EXPLANATION OF CHANGE: The commission considered this comment and agrees that the proposed rule should be clarified to include a time frame for providing notice to the commission of bankruptcy filings. The time frame will ensure the commission has timely notification of actions impacting the telecommunications landscape of Missouri.

COMMENT: Mimi MacDonald of SBC, in SBC's written comments, raised concerns that section (2) of the rule as proposed could result in customers not receiving telecommunications services for a period of time. SBC suggested the proposed rule be amended to require telecommunications companies to file an application for service authority or transfer of assets within forty-five (45) days after the bankruptcy court enters the order approving the transfer of assets. At the public hearing, Natelle Dietrich, on behalf of the commission's staff, stated that the application process tends to happen much more quickly and suggested the proposed rule be modified to allow no more than ten (10) days after the effective date of the bankruptcy court's order for filing the application. At the public hearing, Ms. MacDonald for SBC responded that bankruptcy orders typically become effective in eleven (11) days. She further commented that companies having to make filings in fifty (50) states may need more time; thus, the recommendation for forty-five (45) days.

RESPONSE AND EXPLANATION OF CHANGE: The commission has reviewed the comments and finds that a more limited time for companies to file service authority or transfer of asset applications is in the public interest to ensure customers receive continuous, uninterrupted service. The proposed rule will be modified as proposed by staff and will ultimately allow a company at least twenty-one (21) days to file the application.

COMMENT: Mimi MacDonald of SBC, in SBC's written comments, raised concerns that section (3) of the rule as proposed does not specify when the telecommunications company filing bankruptcy has to provide the information required by this subsection to the commission. SBC suggested the proposed rule be amended to require the telecommunications company filing bankruptcy to provide the information required in this subsection within seventy-five (75) days of the filing of the petition for bankruptcy relief. At the public hearing, Natelle Dietrich, on behalf of the commission's staff, stated that staff does not object to this suggestion.

RESPONSE AND EXPLANATION OF CHANGE: The commission has reviewed the comments and finds that it is appropriate to modify this subsection to include a time frame for filing the required information. By placing a time frame on the filing requirements, the commission will receive timely notice of the planned disposition of facilities located on the premises of another telecommunications company. This requirement will also provide timely notice to the telecommunications company, on whose premises the company filing bankruptcy has facilities, as to the disposition of that property.

COMMENT: Mimi MacDonald of SBC, in SBC's written comments, raised concerns that subsection (D) of section (3) of the proposed rule fails to ensure that the debtor's personal property will be removed by the debtor and at the debtor's expense. SBC proposed language to require the telecommunications company filing bankruptcy to disconnect and remove its personal property from the premises and dispose of such personal property properly. At the public hearing, Natelle Dietrich, on behalf of the commission's staff, stated that staff does not object to this suggestion.

RESPONSE AND EXPLANATION OF CHANGE: The commission has reviewed the comments and finds that it is appropriate to modify this subsection to include a requirement that the telecommunications company filing bankruptcy be responsible for the removal and disposition of its own property. By adding this requirement, the company that owns the equipment will bear the cost and burden of removing and disposing of its property.

4 CSR 240-3.565 Procedure for Telecommunications Companies that File Bankruptcy

(1) Any telecommunications company certificated in Missouri that files bankruptcy or has an affiliate that files bankruptcy shall, within ten (10) working days of filing bankruptcy, provide to the commission:

(A) A notice that the company or an affiliate has filed bankruptcy including:

1. The bankruptcy case number;
2. The bankruptcy filing date;
3. The bankruptcy chapter number; and
4. The bankruptcy court.

(B) If Missouri certificated telecommunications companies have certificated or non-certificated affiliates that file bankruptcy, only one of the Missouri certificated telecommunications companies need provide to the commission the items in paragraphs (1)(A)1.-4. The responsibility of providing the information in paragraphs (1)(A)1.-4. will fall to the carrier first certificated in Missouri. The certificated company providing these items shall also provide the name(s) of its other Missouri certificated affiliate(s).

(2) If the bankruptcy court approves the transfer of customers to another telecommunications company, a copy of the bankruptcy

order shall be provided to the commission with the application for service authority or application for approval to transfer assets. An application for service authority or application for approval to transfer assets may be filed before, but shall be filed no more than ten (10) working days after the effective date of, the bankruptcy court's order approving the transfer of the customers.

(3) If the telecommunications company filing bankruptcy has telecommunications facilities that are located at the premises of another telecommunications company, the company filing bankruptcy shall, within seventy-five (75) days after filing bankruptcy, provide to the commission:

(A) A statement identifying the telecommunications facilities and their locations;

(B) A statement identifying the entities with an interest in the telecommunications facilities;

(C) A statement describing the disposition of the telecommunications facilities and the entity conducting the disposition of the facilities; and

(D) A statement informing the commission of the date when the telecommunications facilities have been or will be disconnected and removed from the premises of the other telecommunications company and disposed of properly.

Title 19—DEPARTMENT OF HEALTH AND SENIOR SERVICES

Division 60—Missouri Health Facilities Review Committee Chapter 50—Certificate of Need Program

ORDER OF RULEMAKING

By the authority vested in the Missouri Health Facilities Review Committee (Committee) under section 197.320, RSMo 2000, the Committee amends a rule as follows:

19 CSR 60-50.300 is amended.

A notice of proposed rulemaking containing the text of the proposed amendment was published in the *Missouri Register* on May 17, 2004 (29 MoReg 846). The section with changes is reprinted here. This proposed amendment becomes effective thirty (30) days after publication in the *Code of State Regulations*.

SUMMARY OF COMMENTS: A public hearing on this proposed amendment was held June 17, 2004. The Certificate of Need Program (CONP) staff, on behalf of the Committee, received three (3) comments on this rule.

COMMENT: J. David Bechtold, representing the Missouri Health Care Association, commented that, in section (9), introduction and placement of the phrase "incurred over a twelve (12)-month period" caused confusion and should not be amended.

RESPONSE AND EXPLANATION OF CHANGE: This section was modified by deleting it from the confusing location and moved to the end of "costs" being referenced.

COMMENT: J. David Bechtold, representing the Missouri Health Care Association, asserted that the Committee did not recognize the cost to the Medicaid Program, which they believed would exceed \$500 in the aggregate. His calculations would result in a claimed public agency impact of \$1,423.50 in additional Medicaid cost for every nonapplicability or approved Medicaid bed. He also postulated that there would be an additional private entity cost which would exceed \$500 in the aggregate; and that this cost represented revenue lost by individual providers due to the construction of unneeded facilities which would in turn reduce the overall occupancy of existing facilities. His calculated example for unneeded, but approved, nursing homes would result in a claimed private entity impact of \$35,405

in lost revenue to an existing 100-bed nursing home for every percentage point drop in occupancy that would occur.

RESPONSE: The adoption of this rule would not require or result in an expenditure of public funds by, or a reduction of public revenues for, any other agency of state government or any political subdivision thereof, when compared to expenses and revenues for these entities prior to adoption of this rule. The Committee's actions do not create additional Medicaid expenses. As for service utilization, it is disingenuous to couple any of the Committee's actions with declining facility occupancy when other countervailing factors, such as the availability of alternative care, changing reimbursement standards and increasing elderly population, so strongly influence institutional selection and use. It is also important to note that the previous Chairman of the Joint Committee on Administrative Rules carefully reviewed all of these proposed changes, and concurred that they would have public and private fiscal notes under \$500, similar to the three other CON rules approved in 2003. No changes have been made as a result of this comment.

COMMENT: Thomas R. Piper, representing the CONP, commented that, in section (9), the phrase "incurred over a twelve (12)-month period" is incorrectly placed and should be moved to after the phrase "and any other capitalizable costs".

RESPONSE AND EXPLANATION OF CHANGE: This section was modified accordingly.

19 CSR 60-50.300 Definitions for the Certificate of Need Process

(9) Health care facility expenditure includes the capital value of new construction or renovation costs, architectural/engineering fees, equipment not in the construction contract, land acquisition costs, consultants'/legal fees, interest during construction, predevelopment costs as defined in section 197.305(13), RSMo, in excess of one hundred fifty thousand dollars (\$150,000), any existing land and building converted to medical use for the first time, and any other capitalizable costs incurred over a twelve (12)-month period as listed on the "Proposed Project Budget" form MO 580-1863.

Title 19—DEPARTMENT OF HEALTH AND SENIOR SERVICES

Division 60—Missouri Health Facilities Review Committee Chapter 50—Certificate of Need Program

ORDER OF RULEMAKING

By the authority vested in the Missouri Health Facilities Review Committee (Committee) under section 197.320, RSMo 2000, the Committee amends a rule as follows:

19 CSR 60-50.400 is amended.

A notice of proposed rulemaking containing the text of the proposed amendment was published in the *Missouri Register* on May 17, 2004 (29 MoReg 846-847). Those sections with changes are reprinted here. This proposed amendment becomes effective thirty (30) days after publication in the *Code of State Regulations*.

SUMMARY OF COMMENTS: A public hearing on this proposed amendment was held June 17, 2004. The Certificate of Need Program (CONP) staff, on behalf of the Committee, received four (4) comments on this rule. In addition, the Joint Committee on Administrative Rules held a two-part hearing on August 24 and 25, 2004, where several recommendations were made.

COMMENT: J. David Bechtold, representing the Missouri Health Care Association, commented that section (3) is inconsistent with statute and other rules as stated, and suggested that the phrase "if the capital expenditure for such bed expansion or replacement exceeds

\$600,000,” be inserted after the phrase “a CON application” to amend and clarify the paragraph.

RESPONSE AND EXPLANATION OF CHANGE: This section was modified accordingly.

COMMENT: J. David Bechtold, representing the Missouri Health Care Association, commented that, in paragraph (4)(F)7., the description of when a CON application is needed should be modified to include “regardless of licensure category” and a minimum capital expenditure of \$600,000 for all long-term care projects, including for projects over 10 beds or 10% of capacity.

RESPONSE: This section maintains a long-standing interpretation that the expanded bed number for exception from CON review must be limited within any two-year period to no more than 10 beds, or 10% of the existing facility capacity, whichever is less, and in no case exceeds \$600,000 in cost. No changes have been made as a result of this comment.

COMMENT: J. David Bechtold, representing the Missouri Health Care Association, commented that, in subsection (4)(G), the description of a CON application exception should be modified to include “regardless of number or category of beds” with a minimum capital expenditure of \$600,000 for projects being separate from projects over 10 beds or 10% of existing capacity.

RESPONSE: This section maintains a long-standing interpretation that the expanded bed number for exemption from CON review must be limited within any two-year period to no more than 10 beds, or 10% of the existing facility capacity, whichever is less, and in no case exceeds \$600,000 in cost. No changes have been made as a result of this comment.

COMMENT: J. David Bechtold, representing the Missouri Health Care Association, asserted that the Committee did not recognize the cost to the Medicaid Program, which they believed would exceed \$500 in the aggregate. His calculations would result in a claimed public agency impact of \$1,423.50 in additional Medicaid cost for every nonapplicability or approved Medicaid bed. He also postulated that there would be an additional private entity cost which would exceed \$500 in the aggregate; and that this cost represented revenue lost by individual providers due to the construction of unneeded facilities which would in turn reduce the overall occupancy of existing facilities. His calculated example for unneeded, but approved, nursing homes would result in a claimed private entity impact of \$35,405 in lost revenue to an existing 100-bed nursing home for every percentage point drop in occupancy that would occur.

RESPONSE: The adoption of this rule would not require or result in an expenditure of public funds by, or a reduction of public revenues for, any other agency of state government or any political subdivision thereof, when compared to expenses and revenues for these entities prior to adoption of this rule. The Committee’s actions do not create additional Medicaid expenses. As for service utilization, it is disingenuous to couple any of the Committee’s actions with declining facility occupancy when other countervailing factors, such as the availability of alternative care, changing reimbursement standards and increasing elderly population, so strongly influence institutional selection and use. It is also important to note that the previous Chairman of the Joint Committee on Administrative Rules carefully reviewed all of these proposed changes, and concurred that they would have public and private fiscal notes under \$500, similar to the three other CON rules approved in 2003. No changes have been made as a result of this comment.

COMMENT: The Joint Committee on Administrative Rules disapproved the phrase “; and” at the end of subsection (4)(F), and disapproved all of subsection (4)(G) in consideration of a pending legal appeal concerning this topic, which in turn would change the punctuation in the remaining subsections (A), (B), (C), (D), (E) and (F) by ending each with a period.

RESPONSE AND EXPLANATION OF CHANGE: Subsection (4)(G) is withdrawn, and the punctuation in the other subsections modified accordingly.

19 CSR 60-50.400 Letter of Intent Process

(3) A LTC bed expansion or replacement as sought pursuant to section 197.318.8 through 197.318.10, RSMo, requires a CON application, if the capital expenditure for such bed expansion or replacement exceeds six hundred thousand dollars (\$600,000), but allows for shortened information requirements and review time frames. When a LOI for a LTC bed expansion, except replacement(s), is filed, the Certificate of Need Program (CONP) staff shall immediately request certification for that facility of average licensed bed occupancy and final Class 1 patient care deficiencies for the most recent six (6) consecutive calendar quarters by the Division of Senior Services and Regulation (DSSR), Department of Health and Senior Services, through a LTC Facility Expansion Certification (Form MO 580-2351) to verify compliance with occupancy and deficiency requirements pursuant to section 197.318.8, RSMo. Occupancy data shall be taken from the DSSR’s most recently published Six-Quarter Occupancy of Intermediate Care and Skilled Nursing Facility (or Residential Care Facility) Licensed Beds reports. For LTC bed expansions or replacements, the sellers and purchasers shall be defined as the owner(s) and operator(s) of the respective facilities, which includes building, land, and license. On the Purchase Agreement (Form MO 580-2352), both the owner(s) and operator(s) of the purchasing and selling facilities should sign.

(4) The CONP staff, as an agent of the Missouri Health Facilities Review Committee (Committee), will review LOIs according to the following provisions:

(A) Major medical equipment is reviewed as an expenditure on the basis of cost, regardless of owners or operators, or location (mobile or stationary).

(B) The CONP staff shall test the LOI for applicability in accordance with statutory provisions for expenditure minimums, exemptions, and exceptions.

(C) If the test verifies that a statutory exception or exemption is met on a proposed project, or is below all applicable expenditure minimums, the committee chair may issue a Non-Applicability CON letter indicating the application review process is complete; otherwise, the CONP staff shall add the proposal to a list of Non-Applicability proposals to be considered at the next regularly scheduled committee meeting.

(D) If an exception or exemption is not met, and if the proposal is above any applicable expenditure minimum, then a CON application will be required for the proposed project.

(E) A Non-Applicability CON letter will be valid subject to the following conditions:

1. Any change in the project scope, including change in type of service, cost, operator, ownership, or site, could void the effectiveness of the letter and require a new review; and

2. Final audited project costs must be provided on a Periodic Progress Report (Form MO 580-1871).

(F) A CON application must be made if:

1. The project involves the development of a new hospital costing one million dollars (\$1,000,000) or more, except for a facility licensed under Chapter 197, RSMo, meeting the requirements described in 42 CFR, section 412.23(e);

2. The project involves the acquisition or replacement of major medical equipment in any setting not licensed under Chapter 198, RSMo, costing one million dollars (\$1,000,000) or more;

3. The project involves the acquisition or replacement of major medical equipment for a health care facility licensed under Chapter 198, RSMo, costing four hundred thousand dollars (\$400,000) or more;

4. The project involves the acquisition of any equipment or beds in a long-term care hospital meeting the requirements found in 42 CFR section 412.23(e) at any cost;

5. The project involves a capital expenditure for renovation, modernization or replacement, but not additional beds, by or on behalf of an existing health care facility licensed under Chapter 198, RSMo, costing six hundred thousand dollars (\$600,000) or more;

6. The project involves either additional LTC (licensed or certified residential care facility I or II, intermediate care facility, or skilled nursing facility) beds or LTC bed expansions or replacements licensed under Chapter 198, RSMo, as defined in section (3) of this rule, costing six hundred thousand dollars (\$600,000) or more; or

7. The project involves the expansion of an existing health care facility as described in subdivisions (1) and (2) of section 197.366, RSMo, that either:

A. Costs six hundred thousand dollars (\$600,000) or more;

or

B. Exceeds ten (10) beds or ten percent (10%) of that facility's existing licensed capacity, whichever is less.