

The Missouri State Archives

Where History Begins

Summer/Fall 2020

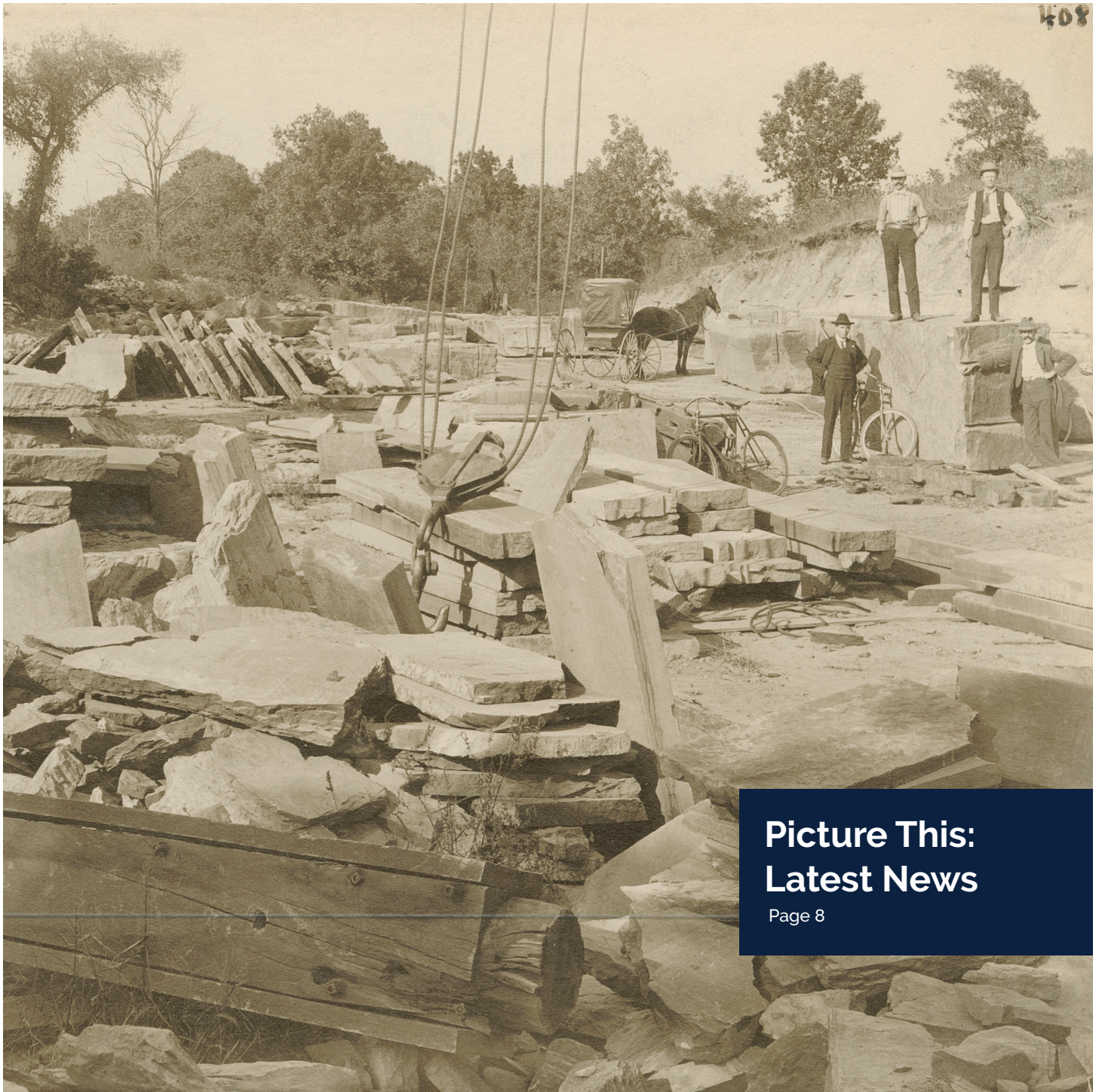

Picture This: Latest News

Page 8

Contents

- 3 From the State Archivist
- 4 Agents of Decay
- 6 Missouri's State Symbols: Floral Emblem
- 8 Picture This: Latest News
- 10 2019 William E. Foley Research Fellowship Report
- 11 New Missouri Census Records and Tax Lists Database
- 12 In Case You Missed It... (Facebook Edition)
- 15 Donations

Missouri State Archives

600 W. Main St.
Jefferson City, MO 65101

(573) 751-3280
www.sos.mo.gov/archives
archives@sos.mo.gov

Monday to Friday
8 a.m. – 5 p.m.
Third Thursday
8 a.m. – 7 p.m.
Second Saturday (September–May)
9 a.m. – 1 p.m.
Second and Fourth Saturdays (June–August)
9 a.m. – 1 p.m.



facebook.com/missouristatearchives



flickr.com/missouristatearchives



The Friends of the Missouri State Archives

The purpose of the Friends of the Missouri State Archives is to render support and assistance to the Missouri State Archives. As a not-for-profit corporation, the Friends organization is supported by memberships and gifts.

Please address correspondence to

Friends of the Missouri State Archives
PO Box 242
Jefferson City, MO 65102
www.friendsofmsa.org

Friends of the Missouri State Archives Board of Directors

Directors

Vicki Myers, President
Gary Collins, Vice President
William Ambrose, Secretary
Tom Holloway, Treasurer

Evie Bresette	Sean Murray
Cathy Dame	Arnold Parks
Nancy Grant	Rachael Preston
Ruth Ann Hager	Bob Priddy
Gary Kremer	Robert M. Sandfort
Nancy Ginn Martin	David Sapp

Ex officio Directors

John R. Ashcroft, Secretary of State
John Dougan, Missouri State Archivist

Staff

Brian Rogers, Principal Assistant for Boards and
Commissions/Newsletter Editor
Email: brian.rogers@sos.mo.gov
Phone: (573) 526-1981

On the Cover

View of the asphaltic sandstone quarry operated by G.H. Walser's Liberal Stone and Coal Company near Liberal, Missouri, c. 1904. From the Department of Natural Resources Geology and Mines Photograph Collection.

From the State Archivist

By John Dougan

When we look back across history, 2020 will undoubtedly be one of those years. The events of the last few months have deeply affected us all, including the Missouri State Archives family. After closing the doors to walk-in visitors on March 24, a small number of employees continued working at the office, pulling emergency requests and responding to phone calls and emails. Others worked from home, and when they couldn't, indexed Missouri Death Certificates that are now available to search through our website. After rearranging workspaces to facilitate social distancing, most staff returned to work in May. This new setup, together with the use of masks, diligent personal hygiene and a strict sick day policy, has so far kept us safe and healthy.

Soon after COVID forced the closure of our research room to in-person visitors, we changed our research request policy to allow individuals up to three remote requests at a time, where in the past we allowed just one. Many of you have used this to your advantage, because in the last few months our website has recorded an extraordinary number of visitors and our reference staff has filled a record number of requests! Little surprise when so many were sheltering at home. When the office reopened in May, we started allowing in-person visitors by appointment only to ensure safe social distancing, a practice that we now also use when scheduling our in-house volunteers.

COVID has even affected our much-loved Friends of the Missouri State Archives' Thursday Evening Speaker Series, requiring us to move new programs online. We now stream these on Facebook Live, while recordings are later available on either Facebook or the Office of the Secretary of State's YouTube channel. A special thank you to Principal Assistant for Boards and Commissions Brian Rogers for spearheading this effort and adding audio/visual equipment technician to his list of position responsibilities.



Over the summer and now into fall, staff have also provided virtual programming for the St. Louis Genealogical Society's Summer Speaker Series and the annual conferences of the Missouri Association of Museums and Archives, the Missouri Library Association and the Federation of Genealogical Societies. Despite the transition of these and other events to a virtual format, our staff remains committed to providing instruction on the use of our records and other archival and records management-related topics.

Looking to the future, next spring we'll host our first all virtual Central Region National History Day in Missouri competition as well as release a video tour of the Missouri State Archives designed as an alternative to the tours we usually provide each year for thousands of third-, fourth- and fifth-grade students.

Despite these difficult times, I'm continually amazed and proud of the Missouri State Archives staff. Their dedication has led to minimal disruption of our activities and services. So, while we look forward to again seeing you in our research room or at a conference, we hope you'll keep those research requests and website visits coming!



The day before Halloween, three of the 10 agents of decay—Mold, Fire and Water—visited the Missouri State Archives. Though we kept them at bay this time, we always have to remain vigilant!

To keep your records safe, look out for the below agents:

1. Inappropriate Temperature

Perhaps the most important aspect of preventive records conservation is monitoring and regulating the storage environment. Anything above 75° F can accelerate chemical reactions and a consistent temperature is preferred to wild fluctuations. When combined with the second agent of decay, temperature is an even more serious threat to collections.

2. Inappropriate Relative Humidity

Relative humidity (RH) is the percent of water vapor in a known volume of air. It's closely connected to temperature and collection damage is likely when both are high. Like temperature, it's also important to maintain consistent RH and to make sure any changes are gradual. Storage spaces should never exceed 50-55% RH as mold is a major risk above this level.

3. Light

Light—particularly of the UV variety—is another damaging, but preventive conservation issue. Installing UV filters on windows and lights, maintaining low overall light levels and storing light-sensitive materials in the dark (including in boxes) keeps items from fading and degrading.

4. Pests

Insects and rodents love to burrow and nest in paper, damaging or destroying records and generally acting as boorish guests. Mold also infests and feeds on paper, leaving stains and weak areas. Routinely monitor storage spaces and collections to prevent infestations. If found, the type of pest and degree of infestation should determine control measures.

5. Physical Forces

In the case of archives, handling accidents usually result from physical forces. Breaking off a small piece



Mold, Fire and Water visiting the Missouri State Archives before Halloween.

of paper when turning a book page, for example. To mitigate risk, use proper handling procedures.

6. Contaminants and Pollutants

Airborne pollutants and particulate contamination pose yet another collection threat. Just the oxygen in the air drives chemical reactions and the off-gassing of objects as they age can cross-contaminate (which is why steel shelving is recommended over wood shelving). Particulates are any foreign matter deposited on an object's surface: dust, dirt, residues, fingerprints, even strawberry jam! Tape is one of the most insidious because it's difficult to remove without causing further damage. Strive to prevent contaminant/pollutant damage, because it can't be undone.

7. Water

Water is the next fearsome archival foe. Floods, burst pipes, backed-up drains, even a spilled cup of coffee can cause damage to paper and other collection items. When water subsides, there's also a risk of mold (see agents 1, 2 and 4) and water contaminant staining. A quick response is necessary to ensure any damage is contained and mitigated. Freeze paper-based collections until treatment to prevent ink bleeding, paper disintegration and possible mold growth.

8. Fire

Fire is one of the scariest agents because it poses devastating risk. Thankfully, however, fires are rare. Not only can flames and smoke destroy a collection,

of Decay



Local Records Program Archivist Lisa Janes drying a record book after a 2017 flood of the Carter County Courthouse in Van Buren.



Nineteenth century New Madrid County record books damaged by a mold infestation.

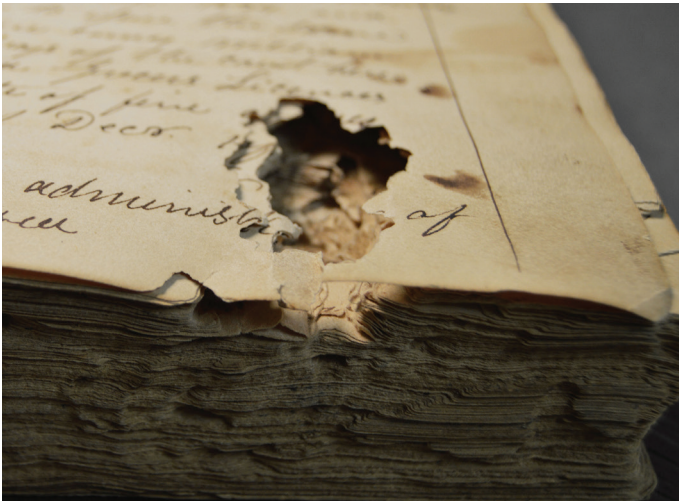

Crawford County Probate Court record book dating from the 1830s following a termite infestation.

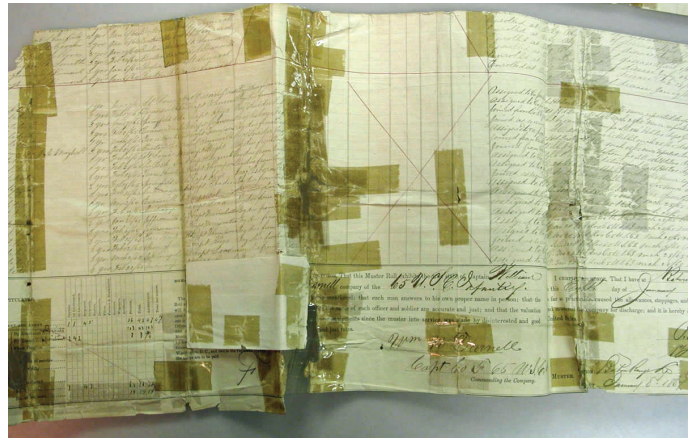

Tape repaired Civil War-era Muster Roll of Missouri's 65th Regiment of United States Colored Troops (USCT).

fires also usually lead to water damage when extinguished. While this exchanges one agent for another, wet records can be recovered. Ashes cannot.

9. Theft, Vandalism and Dislocation

These are, unfortunately, not uncommon issues for archives and other record repositories. Whether it's "autograph hunters," a misplaced sense of ownership or pure criminality, theft is a major risk and, along with dislocation (misplaced or lost records), unfixable. Though vandalism can sometimes be repaired, when records are gone, they're gone. Security measures

and proper tracking procedures are the best way to combat these issues.

10. Neglect

Last, but certainly not least, is neglect. Closely monitoring collections is a must or the other agents will run rampant. This includes appropriate environmental management, pest controls, security procedures and a regularly updated disaster plan.

Missouri's State Symbols: Floral Emblem

By Erika Woehlk, Visual Materials Archivist

On March 16, 1923, Gov. Arthur M. Hyde signed a bill making the hawthorn blossom the official Missouri state floral emblem. Yet for decades prior, Missourians struggled to nominate and approve a state flower.

The story begins in 1893 with the Chicago World's Fair, formally the Columbian Exposition. The Fair's organizers asked every state to choose a representative flower for floral displays in the Exposition's Horticulture Building. In a poll run by the *St. Louis Globe-Democrat*, Missouri readers suggested dog fennel, violet, wild rose, crabapple blossom and many more. Out of 9,582 votes, the crabapple blossom won by a wide margin.

Following the Exposition, according to one 1901 newspaper report, there was a campaign for Missouri schoolchildren to select a state floral emblem. They came up with the goldenrod. The yellow flower was widely used in early 20th century wedding decorations, so it is not as odd a choice as one might think. It was also not erroneously associated with allergies as it is today. There was even a parallel campaign urging that the goldenrods be adopted as America's national floral emblem.

Many publications advertised this word-of-mouth, unofficial state flower as official in the following years, including *Tiemann's Symbolical Reference Chart* used in libraries nationwide as a state symbol reference source. In actual fact, the Missouri Legislature had *not* adopted the goldenrod as a floral emblem.

Supporters revived the campaign to adopt the goldenrod in 1915 when an official state flower was to decorate Missouri's Panama-Pacific Exposition train car. The Missouri Historical Society in St. Louis declared it to be the goldenrod, although Secretary of State Cornelius Roach and Shaw's Botanical Garden both correctly stated there was no official state flower.

Harkening back to the Columbian Exposition, the State Historical Society, State Horticultural Society, Daughters of the American Revolution and other organizations joined together to request that the wild crabapple become the official state flower in 1917, though their resolution failed. Two years later, they made another

attempt for the crabapple, but Senate Bill 441 died with a vote of 39 to 40. Later that year, the Daughters of the American Revolution switched flower allegiances and lobbied the Legislature to approve the daisy as the state flower. That effort, too, failed. The daisy supporters persisted for two more years, however, and Sen. Frank Warner introduced a new bill on their behalf in 1921. Then came the real debate.

An anonymous petition made its way to the General Assembly in February 1921 advocating that the hawthorn, aka the "red haw," become the state's official floral emblem. Floor debate ensued later that month. Daisy supporters pinned daisy flowers to the jackets of the legislators on their side. Hawthorn supporters turned out in numbers as well. The hawthorn spokesperson called the daisy an "alien flower." (Ox-eye daisies are an imported species not native to North America, let alone Missouri.) Neither side could garner a majority of supporters; the hawthorn bill failed in the House with a vote of 68 to 44, while the daisy bill never even made it out of committee.

The matter came up once more during the 1923 legislative session. Supporters submitted another bill that would designate the hawthorn blossom as Missouri's official state flower. (Actually, there were two bills, but one became the preferred.) This time, the bill was unopposed, passing unanimously in the House with a vote of 130 to zero and in the Senate, 25 to one, the lone naysayer being Sen. O.A. Pickett of the Fourth District (Harrison, Livingston, Mercer, Grundy and Putnam counties). Gov. Hyde signed the bill into law on March 16, 1923. Finally, it was official! After so many pivots, Missouri's state floral emblem was codified into law as the hawthorn blossom.



Fun fact: the largest book ever made in the United States (as of 1893) was a blank subscription book for *Chaperone Magazine*, a St. Louis publication owned by female entrepreneur Annie Orff. The book weighed 163 pounds and measured over five feet wide. Displayed at the Columbian Exposition in Chicago, its front cover was illustrated with Missouri's chosen flower for the Exposition: the crabapple blossom.

The above illustration by Brown of the St. Louis Compton Company appeared in *Chaperone Magazine*, Vol. 8 (Sept. 1893-Feb. 1894). It may reflect the book's cover. *Courtesy of St. Louis Mercantile Library.*



This 1908 postcard incorrectly identifies the goldenrod as Missouri's state flower. The poem reads, "Over Missouri's sun-kissed plain | There grows the symbol of her reign. | Her scepter is fair golden rod | It waves o'er rich and verdant sod." *From the Bob Priddy Manuscript Collection.*

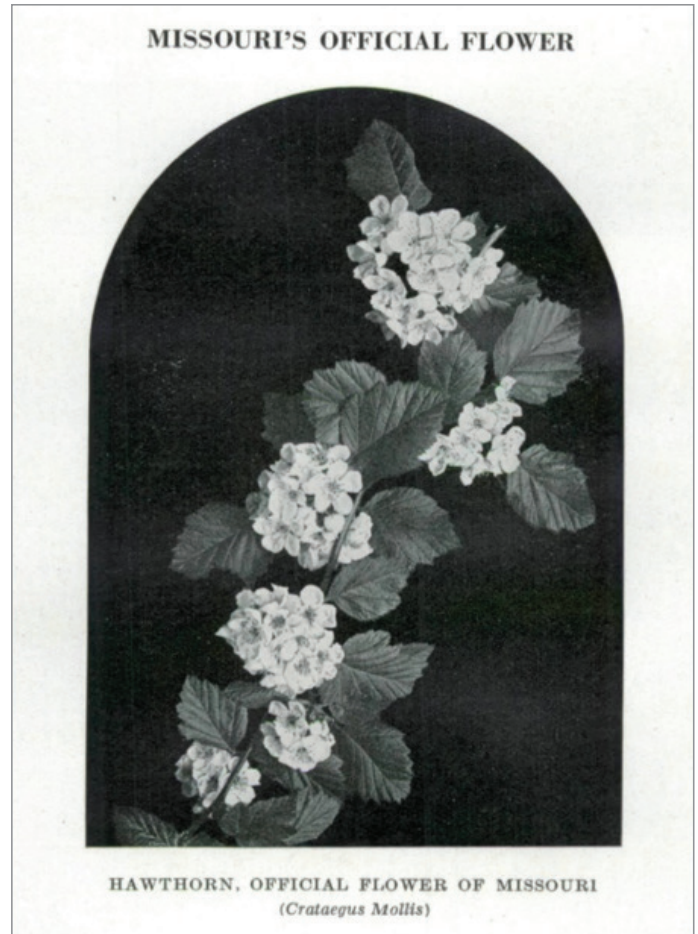

The 1923-24 *Official Manual of the State of Missouri* was the first edition to identify the hawthorn as the state flower, including this illustration of *Crataegus mollis*, the downy or red hawthorn. *From the Publications, Non-Portrait Photograph Collection.*



Illustration of the ox-eye daisy (*Chrysanthemum leucanthemum*), from a 19th century Dutch publication called *Flora Batava, of Afbeelding en beschrijving van Nederlandsche Gewassen.*

Picture This: Latest News

By Erika Woehlk, Visual Materials Archivist

The Missouri State Archives takes advantage of several online platforms to increase public access to photograph collections, each offering the user unique features. Listed here are few of our favorite latest additions.



Ella Ewing (left) and her mother Anna pose for a studio portrait in Scotland County, c. 1899. Known as the "Missouri Giantess," Ella reportedly reached a height of eight feet, four inches and toured with Barnum and Bailey's Circus for a time. *From the Vanishing Missouri Photograph Collection.*

Missouri Digital Heritage: Vanishing Missouri

Every *Official Manual of the State of Missouri* (aka the *Blue Book*) published between 1987 and 2017 has included images from the winners of a photograph contest run by the Office of the Secretary of State. For three iterations—in 1991, 1993 and 1995—it was the "Vanishing Missouri" contest, wherein contestants from all over the state submitted photographs depicting "vanishing" ways of life. In just these three years, the office received over 1,700 entries, with popular subjects

including agriculture, family, homes, business, towns/cities, schools and famous Missourians, such as Ella Ewing (left). Most of the images date from the 1940s and earlier.

The Missouri State Archives recently digitized all Vanishing Missouri entries and they are now accessible on Missouri Digital Heritage. To view this collection, visit www.sos.mo.gov/mdh and follow the link in the "Latest Updates" section.



Oregon County's Greer Spring and Greer Spring Cave, c. 1944. The spring flows into the nearby Eleven Point River. *From the Department of Natural Resources Geology and Mines Photograph Collection.*

Missouri Digital Heritage: Missouri Rocks!

In December 2019, the Missouri State Archives' new Department of Natural Resources Geology and Mines Photograph Collection went live on Missouri Digital Heritage. We know what you're thinking: these are just boring old pictures of rocks, right? Wrong! This collection contains nearly 2,200 images, including stunning landscapes, like this photograph of Greer Spring (above). There are also plenty of images for historians interested in Missouri's stone and mineral industry, such as the photograph showing the operations of a quarry west of Trenton (right above). The collection even includes images that could be of use to the tourism industry (right middle). Finally, if you really do "dig" rocks, there are certainly enough specimen photographs to satisfy both the amateur and professional geologist (right bottom).

To view the collection, visit www.sos.mo.gov/mdh and select the collection link in the "Latest Updates" section.



A group poses in an unidentified Bethany Falls limestone quarry west of Trenton in Grundy County, c. 1910. Much of the excavated stone was likely used to produce cement, chat or lime. *From the Department of Natural Resources Geology and Mines Photograph Collection.*



Four women stand at the edge of Round Spring in Shannon County, c. 1944. To this day, the county is a popular destination for those interested in natural springs and scenic rivers. *From the Department of Natural Resources Geology and Mines Photograph Collection.*



Studio shot of a sandstone sample encrusted with galena crystals, Missouri's official state mineral, c. 1902. Specimen taken from Jasper County's now closed Little Nugget Mine. *From the Department of Natural Resources Geology and Mines Photograph Collection.*



Facebook

Many of you know that the Missouri State Archives runs a Facebook page frequently featuring photographs and announcing new additions to our various online platforms. Like or follow us today at www.facebook.com/missouristatearchives to stay up-to-date!

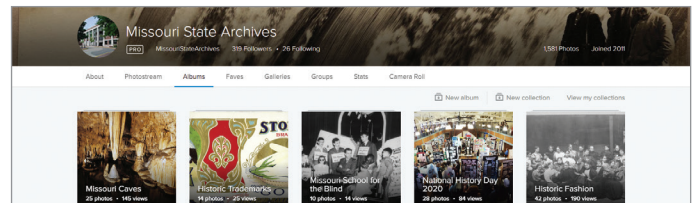

Flickr

The Missouri State Archives has maintained a Flickr page for nearly a decade. With the easy access it offers to photographs, the site is an ideal platform for sharing popular interest images with a wide audience. Collections are organized into topical albums documenting Missouri's photographic history, including Missouri Caves, Historic Trademarks, the 1954 Missouri State Penitentiary Riot and many more.

In the last year alone, our Flickr page received 489,385 page views from visitors all around the world. If there's a visual topic you would like the Archives to explore, let us know and help us reach 500,000 in 2021!

Visit our Flickr page at www.flickr.com/photos/missouristatearchives/albums/.

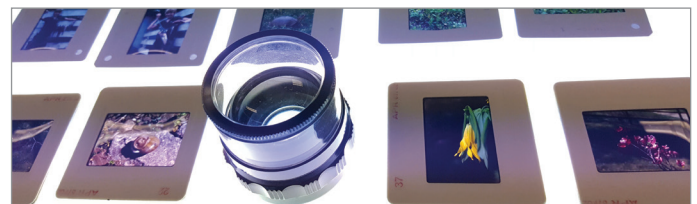

New Photographs Webpage

In late May, the Missouri State Archives launched a new webpage devoted exclusively to our photograph collections. Visit the page at www.sos.mo.gov/archives/resources/photographs to learn about our approximate 829,500 photographs and images, the vast majority of which are not yet available online.

2019 William E. Foley Research Fellowship Report

By Daniel Farrell, Ph.D. Candidate in History, University of Cincinnati



During my three-weeks at the Missouri State Archives in August 2020, I spent much of my time using RG133, the papers of the Office of the Adjutant General. Rather unexpectedly, I specifically mined the Civil War-era regimental returns of the Enrolled Missouri Militia (RG133.13). Though the finding aid to these returns sparked an interest ahead of my arrival, I believed the collection would be of limited relevance to my research on civil-military relations, guerilla warfare and notions of loyalty and disloyalty to the federal government during the American Civil War.

I am happy to report that this was not the case! The EMM regimental returns contain hundreds of relevant documents and many more that could be of use to others. The records are rich in details about guerilla warfare in Missouri, including obscure clashes and engagements with notable individuals such as Bill Anderson and John A. Poindexter. References to guerillas and bushwhackers also routinely appear in accompanying correspondence, speaking to the frequency with which they harassed Union troops and their constant presence in the minds of federal military officials. Missouri citizens, through petitions, similarly complained about irregular warfare. The EMM records contain a litany of documents written by officers, soldiers and civilians accusing one another of disloyalty to the Union, shedding light on how difficult it was to ensure genuine unionists staffed the militia.

The EMM regimental returns provide insight into other civil-military relations as well. While guerrilla warfare was the dominant theme, I uncovered records documenting arrests, the assessment of punitive taxes, the registration of disloyal citizens and the refugee problem. Militiamen also harassed civilians on occasion, creating outcries for

more discipline. Similar items are in the smaller, related regimental returns. Most notably RG133.24, the returns of the Provisional Enrolled Missouri Militia, and RG133.17, those of the Missouri State Militia. While undoubtedly incomplete, all these regimental returns provide a rich assortment of documents speaking to the contested nature of loyalty in Missouri.

Also worth highlighting briefly, I sifted through many documents potentially of interest to other Missouri Civil War historians. Desertion and military discipline are common themes in these collections. Resignation letters and discharge requests give insight into the private lives of soldiers and officers suffering from injury, illness, indigency and family problems. Post-war correspondence routinely highlights attempts to secure pensions, sometimes well into the 1920s, and would be of interest to anyone studying the state's Civil War veterans. Even records related to combating Sterling Price occasionally surface. Overall, my time at the Missouri State Archives was exceedingly productive, with RG133 playing a crucial role in my research, as it will for anyone studying Missouri's Civil War experience.

About the author: Daniel Farrell is the recipient of the Friends of the Missouri State Archives' 2019 William E. Foley Research Fellowship and a Ph.D. candidate in history at the University of Cincinnati. He visited the Missouri State Archives in August 2020 in researching his tentatively titled doctoral thesis, *Assessing Loyalty, Punishing Treason: The Arresting and Jailing of Civilians under United States Martial Law during the American Civil War*.

Visit www.sos.mo.gov/archives/education/WEF for details on how to apply for the Friends of the Missouri State Archives' 2021 William E. Foley Fellowship.

New Missouri Census Records and Tax Lists Database

By Christina Miller, Reference Services Manager

Over the last seven years, Missouri State Archives' staff and volunteers digitized and indexed many census records not only in our collection, but from that of the Missouri Historical Society Library and Research Center as well. The ultimate goal of this partnership was realized at the beginning of July with the release our new Missouri Census Records and Tax Lists Database! Found online at <https://s1.sos.mo.gov/records/archives/archivesdb/census/Default.aspx>, this resource contains select territorial, state and special census records, plus the federal mortality schedules and many early 19th century tax lists. Additionally, it provides digital access to unindexed—but browseable—images of federal agricultural and manufacturing/industrial schedules.

Above the searchable database interface, visitors to the site will notice links to pages with information about federal, territorial, state and special census records, including if they are available for research purposes and/or indexed. We continue to digitize and index additional census records, so check these links often for updates.

Database users can search by name, county, record series, year or age range, gender, race and even by a notes field, which sometimes contains entries such as "slave" or "asylum." Because not all these records include gender, age or race, it is best to omit this information from an initial search, adding it only when necessary. Keep in mind that, like with all our databases, spelling on the original documents was fluid, leading to errors in both the original records and any indexes. If search results are limited, play around with the "Starts with," "Ends with" and "Contains" options in the name fields. Those looking for a specific type of record can also select it from the "Series" dropdown menu.

So what records are in this new database?...

Federal Non-Population Census Records – The database includes indexed federal mortality schedules taken in 1850, 1860, 1870 and 1880, along with unindexed, but browseable, images of the agricultural and manufacturing/industrial schedules recorded in the same years. Containing more than 100,000 names, the mortality schedules are the largest record series now in the database. They list all individuals who died between June 1 and May 31 of the census year. For instance, the 1850 mortality schedule lists all individuals who died between June 1, 1849, and May 31, 1850. Selecting

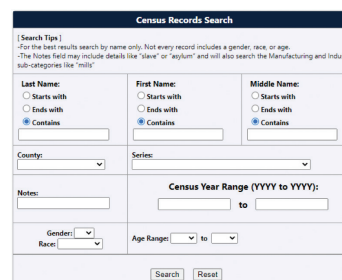

"Mortality Schedules" in the "Series" dropdown menu will also enable a search of the "Cause of Death" field. Because the agricultural and manufacturing/industrial schedules are not yet indexed, when they are selected from the "Series" dropdown menu, users do not have the ability to search by name.

Territorial Census Records/Tax Lists – There are only a few surviving territorial census records from the period 1752 to 1819, and only a small number of these are indexed, though additional indexes are on the way. Territorial tax lists, recorded 1814 to 1819, are a good substitute in the absence of a census. The Missouri State Archives' available territorial tax lists are indexed, but researchers should note that additional tax records might be available at the county level.

State Census Records/Tax Lists – The state of Missouri called for census enumerations at irregular intervals between 1824 and 1844, and then every four years thereafter through 1876. The earliest that survives, however, is from 1840, though for some counties, abstracts are all that are available. Most of these records are not yet indexed. As with the territorial tax lists, state tax lists are a good substitute when census records are not available. At the time of printing, only two are indexed, but surviving tax lists recorded between 1820 and 1830 may be added in the future.

Special Census Records – Missouri cities and towns sometimes take a special census to determine significant population changes between federal and/or state census enumerations. Similar to the state census records, many of these are filed as abstracts only, though all records that include names are indexed and found in the database.

For questions about the database or to request a search of census records or tax lists not yet indexed, email our reference staff at archives@sos.mo.gov.

In Case You Missed It

The Missouri State Archives has recently made a concerted effort to improve the quality and consistency of our Facebook content. In the last year alone, we've added nearly 1,500 new page likes, bringing us to just under 8,500 in total. Thanks to everyone who's "liked" our page, but for those that haven't, below are a few of our more popular posts since the release of our last newsletter. Enjoy!

Missouri Penitentiary
JEFFERSON CITY, MO.
No. 21669
APR 24 1919

Kate Richards O'Hare
M. Lewis

Height	5' 11"	73.6
Out. Arm	6.7-1	
Trunk	22.9	
Leg	18.6	
Wrist	13.7	
Cl. Wrist	13.0	
Forearm	5.6	
L. n. Finger	2.3-8	
L. I. Finger	1.0	
Fernum	9.4-0	
Head	17.1	13
Chin	1.7	11

Meas'd June 15-1917 Meas'd by *A. E. Wallace*
MARKS, SCARS, MOLES, ETC.
Scars in scar area

Kate Richards O'Hare's Bertillon measurements, recorded April 24, 1919. From the Missouri State Penitentiary Collection.



Left: Photographic portrait of Annie Knowles Fisher taken in 1921. Courtesy of the Missouri State Historical Society.

Bottom: 1938 Missouri Death Certificate of Annie Knowles Fisher.

MISSOURI STATE BOARD OF HEALTH
BUREAU OF VITAL STATISTICS
CERTIFICATE OF DEATH

1. PLACE OF BIRTH: *Boone Co. Mo.*
2. PLACE OF DEATH: *Boone Co. Mo.*
3. DATE OF DEATH: *Aug 3 1938*
4. SEX: *Female*
5. AGE: *68*
6. OCCUPATION: *Cook*
7. MARITAL STATUS: *Widow*
8. CAUSE OF DEATH: *Angina pectoris with degenerative atherosclerosis*
9. PLACE OF BURIAL: *Columbia Park Cemetery*
10. SIGNATURE OF DECEASED: *Annie Knowles Fisher*
11. SIGNATURE OF WITNESSES: *Robert ...*
12. SIGNATURE OF PHYSICIAN: *...*
13. SIGNATURE OF MINISTER: *...*
14. SIGNATURE OF CORONER: *...*
15. SIGNATURE OF JURY: *...*
16. SIGNATURE OF DEPUTY: *...*
17. SIGNATURE OF CLERK: *...*
18. SIGNATURE OF REGISTRAR: *...*
19. SIGNATURE OF ASSISTANT REGISTRAR: *...*
20. SIGNATURE OF CHIEF CLERK: *...*
21. SIGNATURE OF CLERK: *...*
22. SIGNATURE OF ASSISTANT CLERK: *...*
23. SIGNATURE OF CLERK: *...*
24. SIGNATURE OF ASSISTANT CLERK: *...*
25. SIGNATURE OF CLERK: *...*
26. SIGNATURE OF ASSISTANT CLERK: *...*
27. SIGNATURE OF CLERK: *...*
28. SIGNATURE OF ASSISTANT CLERK: *...*
29. SIGNATURE OF CLERK: *...*
30. SIGNATURE OF ASSISTANT CLERK: *...*

William Howard Taft when he visited Sedalia. By 1919, Fisher was making \$500 a month through the sale of her biscuits alone. With her earnings, she bought properties around Columbia in Boone County and rented them out to African American families who otherwise couldn't find housing. Fisher died in 1938 with an estimated net worth of \$100,000 and is buried in Columbia's Memorial Park Cemetery.

From March 4, 2020 – Kate Richards O'Hare

After activist Kate Richards O'Hare gave a 1919 anti-war speech in Bowman, North Dakota, a federal court convicted her of "Obstructing Enlistment Service," a violation of the 1917 Espionage Act, and she was sentenced to five years in Jefferson City's Missouri State Penitentiary because there were no federal prisons for women at that time. While incarcerated, she worked with fellow inmates Emma Goldman and Gabriella Segata Antolini to improve prison conditions, and was successful in starting a night school and library for use by female inmates. Discharged on May 20, 1920, after President Woodrow Wilson commuted her sentence, O'Hare worked to free other prisoners convicted of violating the Espionage Act and remained a prison reform advocate for the rest of her life.

From March 10, 2020 – Annie Knowles Fisher

Annie Knowles Fisher was a noted Boone County cook, caterer and entrepreneur most famous for her "Old Missouri Style" beaten biscuits. She hosted many notable events, including a 1911 dinner in honor of President



Left: St. Joseph's Pony Express Monument, sculpted by Hermon Atkins MacNeil in 1940 to commemorate the 80th anniversary of the historic mail service. From the Publications, Non-Portrait Photograph Collection.

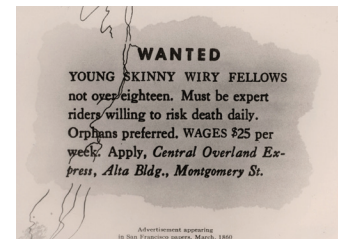

Right: Advertisement appearing in a March 1860 San Francisco newspaper seeking Pony Express riders. From the Publications, Non-Portrait Photograph Collection.

From April 3, 2020 – Pony Express

On this day in 1860, the short-lived Pony Express started its first run from St. Joseph. Charged with carrying mail all the way to Sacramento, California, riders would change horses every 10 miles to make deliveries in a then-unprecedented amount of time. The Pony Express disbanded in October 1861 due to the increased use of telegraph lines during the Civil War, but in the just one-and-a-half-years of its existence, it carried approximately 35,000 letters.

... (Facebook Edition)

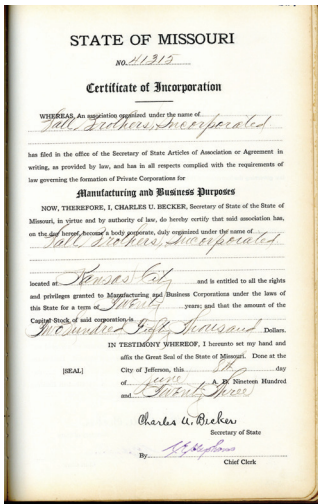

Incorporation certificate of "Hall Brothers Incorporated," the precursor of today's Hallmark Cards Inc., dated June 8, 1923. From the Secretary of State's Business Services Division Collection.

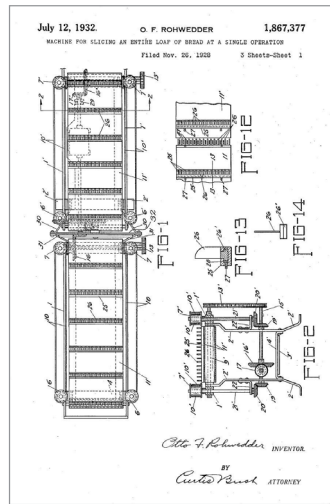

Detailed drawing of Otto Rohwedder's bread slicing machine. Courtesy of the U.S. Patent and Trademark Office.

From June 8, 2020 – Hallmark

On this day in 1923, Joyce C. Hall founded Hall Brothers Inc., the predecessor of today's Hallmark Cards Inc. Hall moved to Kansas City in 1910 where he sold greeting cards door to door before opening a storefront with his brothers in 1913. After the store burned in 1915, he bought an engraving business and began printing his own cards. The enterprise proved lucrative and he formed the company with his brothers in 1923. Renamed Hallmark in 1928, it's now the largest greeting card manufacturer in the United States.



A Newton County man observing the "Hornet Spook Light." Though never printed, noted photographer Gerald Massie submitted the image to *Look Magazine* along with a story in 1964. From the Gerald Massie Photograph Collection.

From July 2, 2020 – Joplin Spook Light

Today, we celebrate World UFO Day because the oft-discussed Roswell, New Mexico, crash occurred on this day in 1947. We here in Missouri have a few of our own legendary UFO sightings, including the "Hornet Spook Light," a purported glowing orb frequently seen near the Oklahoma border in Newton County. It's been a persistent folktale in the region since the late-19th century.

From July 7, 2020 – Sliced Bread

Did you know that Missouri was home to the first commercially available sliced bread? On this day in 1928, the Chillicothe Baking Company sold the first sliced loaf. Four years later, in 1932, Iowan Otto Rohwedder patented a machine that not only sliced, but wrapped the bread as well. The company purchased one, using it to produce its popular Kleen Maid Sliced Bread. Happy sliced bread day, Missouri!



Construction of the Gateway Arch in St. Louis, dated July 8, 1965. From the Missouri Department of Transportation Collection.

From July 8, 2020 – Arch Construction

On this day in 1965, an unknown photographer snapped this pic of the Gateway Arch under construction. Although now an iconic part of the St. Louis riverscape, it looks a little odd here without the finishing touches.



Route map from the Missouri State Highway Commission's 1922 Annual Report. From the Missouri Department of Transportation Collection.

From Aug. 4, 2020 – State Highway Commission

On this day in 1921, to commemorate Missouri's first 100 years of statehood, Gov. Arthur M. Hyde signed the Centennial Road Law during a special legislative session, creating the first bipartisan State Highway Commission. The measure empowered the commission to locate, design, construct and maintain a statewide public highway system, the basis of which we still use today.

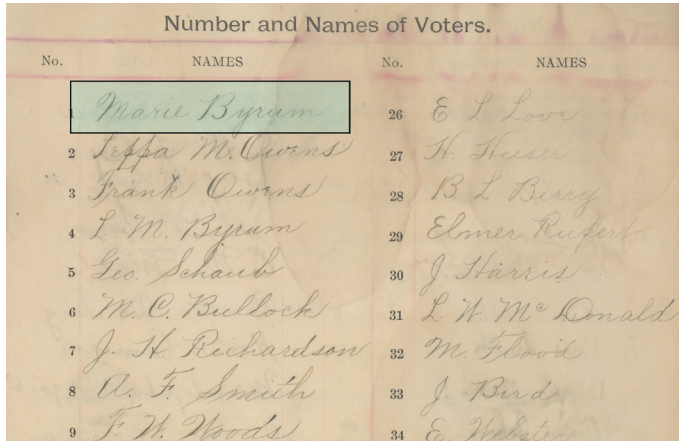

Hannibal city poll book entry of Marie Byrum, the first woman to vote in Missouri, dated August 31, 1920. From the Marie Byrum Manuscript Collection.

From Aug. 31, 2020 – Marie Byrum

On this day in 1920, just five days after the ratification of the 19th Amendment, 26-year-old Marie Byrum became the first woman to vote in Missouri when she cast her ballot in a special election to fill a vacancy on the Hannibal City Council. The election judge overseeing the contest also happened to be her father-in-law, ensuring she was at the front of the line when her polling place opened.



From Oct. 16, 2020 – Walt Disney

Did you know that today in Missouri, it's "Walt Disney – 'Day to Dream' Day?" Born in Chicago, Disney moved with his family to Marceline, Missouri, in 1906 and then to Kansas City in 1911. It was in Kansas City where Walt fell in love with theater, enrolled in Saturday courses at the Kansas City Art Institute and took his first correspondence course in cartooning. He eventually found work as an animator and cartoonist with local studios before moving to Los Angeles in 1923, where he built his cartoon empire.

Undated photograph of animator Walt Disney fishing with children dressed as famous fictional Missourians Tom Sawyer and Becky Thatcher. From the Publications, Portraits Photograph Collection.



Speaker Series Notice



This year's COVID-19 pandemic greatly affected all of our usual outreach activities, including the beloved *Thursday Evening Speaker Series*. Although circumstances still prevent us from hosting in-person public programs, we now have the ability to stream these presentations on Facebook Live. To watch, simply visit www.facebook.com/missouristatearchives/live at the scheduled time (no Facebook account required).

We're hard at work scheduling 2021 offerings, so check our online event calendar in the coming weeks for more details (www.sos.mo.gov/archives/about/calendar.asp). In the meantime, recordings of many past programs are available to view on both our Facebook page and the Office of the Secretary of State's YouTube channel!

Donations to the Friends of the Missouri State Archives

(March 1, 2020 to October 31, 2020)

Harry S. Truman (\$1,000)

Tom Hobbs, Greenfield

Thomas Hart Benton (\$250)

Heinz & Mary Lou Woehlk, Kirksville

Mark Twain (\$100)

Cynthia Amann, Jefferson City

Cathy Dame, Lebanon

Carol Kohnen, Creve Coeur

Patricia Kroger, Florissant

Patrick & Marianne Mills, Jefferson City

Cathy & Alex Primm, Springfield

Greg & Vicki Schildmeyer, Jefferson City

Larry & JoAnn Steinmetz, Jefferson City

Lynda & Don Stubblefield, Jefferson City

Fred Vahle, Warrenton

Laura Ingalls Wilder (\$50)

Don Cullimore, Fayette

Rosemary Gamblin, Pembroke Pines, FL

Claudia McCarthy, Lone Jack

Robert Murrell, Springfield, VA

Gwen Prince, Lee's Summit

Lewis & Clark (\$25)

Tracey Auer, Valley Park

Judy Bates, Scottsdale, AZ

Clara Bolden, Jefferson City

Marilyn Brennan, Ballwin

Paul Crede, Westphalia

Barb Francis, Alviso, CA

Harold & Glennie Goser, Jefferson City

Val Henson, Ellsinore

Dee Mathews, Independence

Judy Osborn-Hill, Greenville

Nancy Ottinger, Jefferson City
Brent Schondelmeyer, Independence

Kelly & Ryan Smith, Boonville

Karen Steely, Vancouver, WA

Sharyl Swope, Portland, OR

Institutional Memberships

Midwest Genealogy Center

Missouri Historical Society Library &

Research Center

In Memoriam

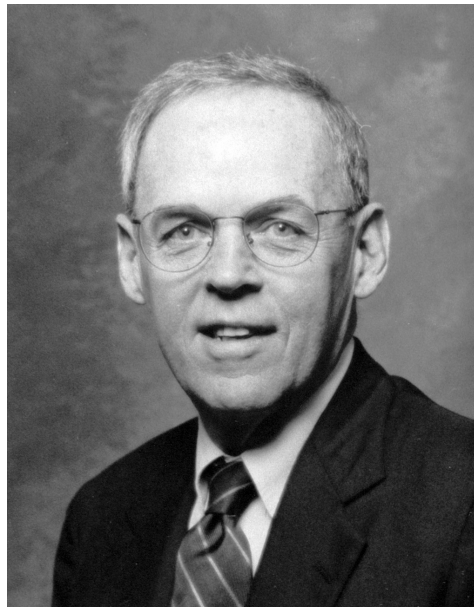

Left: Portrait of then-Rep. Wayne Goode from the 1963-64 Official Manual of the State of Missouri. *From the Publications, Portrait Photograph Collection.*

Right: Recent, though undated, portrait of Sen. Wayne Goode. *From the Publications, Portrait Photograph Collection.*

We were saddened to learn recently that longtime Friends of the Missouri State Archives board member and Missouri legislator Wayne Goode passed away on Saturday, Oct. 3, 2020, at the age of 83. Since his days in the Missouri State Capitol, Senator Goode was

always a strong advocate for the Archives and its mission to safeguard and provide access to the records of the state. Archives staff and the Friends of the Missouri State Archives' board of directors deeply appreciate his legacy and support.

Become a Member of the Friends of the Missouri State Archives

With the support of our "Friends," the Missouri State Archives fosters an appreciation of Missouri history by sponsoring educational and entertaining programs, and making accessible materials from the state's largest collection of original documents, maps and photographs.

Yes, I want to support the appreciation of Missouri's heritage by assisting the Friends of the Missouri State Archives:

\$25 Lewis & Clark Friend **\$40** Family Membership **\$50** Laura Ingalls Wilder Contributor
 \$75 Daniel Boone Supporter **\$100** Mark Twain Benefactor **\$250** Dred & Harriet Scott Associate
 \$500 Thomas Hart Benton Patron **\$1,000** Harry S. Truman Society

Name: _____

Address: _____

City: _____ State: _____ Zip: _____

Email: _____ Receive newsletter by e-mail? Yes No

Telephone Number (with area code): _____ This is a: New Membership Renewal

Make check payable to: Friends of the Missouri State Archives

Mail to: Friends of the Missouri State Archives, PO Box 242, Jefferson City, MO 65102

The Friends of the Missouri State Archives is a 501(c)(3) not-for-profit organization.